

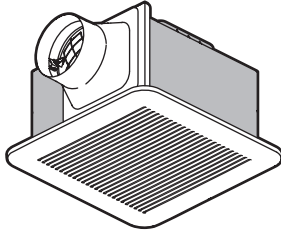

Installation and Operating Instructions

安装使用说明书



Ventilating Fan

换气扇

Model No.	17CUH	24CUH
型号	24CDH	24CHH

READ AND SAVE THESE INSTRUCTIONS

Thank you very much for purchasing this KDK product.

Please read these instructions especially "Safety Instructions" and "Installation Cautions" carefully before attempting to install, operate or service the KDK product. Failure to comply with instructions could result in personal injury or property damage.

Please explain to users how to operate and maintain the product after the installation, and this booklet should be presented to users.

Please retain this booklet for future reference.

阅读并保管好此说明书

感谢您购买本 KDK 产品。

安装、使用和维护 KDK 产品前，请仔细阅读本安装使用说明书，特别是“安全指引”和“安装注意事项”部分。

不遵照此说明书进行操作有可能导致人员受伤或财产损失。

安装完成后，请向顾客说明如何使用和维护本产品，并将此说明书交给顾客保管。

请妥善保管好此说明书以备日后参考。



- Disconnect the power supply until blade is stationary before cleaning and maintenance.
在清洁和维护前，请确保换气扇的电源已经关闭且扇叶停止转动。
- This appliance is not intended for use by persons (including children) with reduced physical, sensory or mental capabilities, or lack of experience and knowledge, unless they have been given supervision or instruction concerning use of the appliance by a person responsible for their safety. Children should be supervised to ensure that they do not play with the appliance.
本设备不适合身体、感官或精神能力下降，或缺乏经验和知识的人员（包括儿童）使用，除非负责其安全的人员对其使用设备进行了监督或指导。应监督儿童确保其不玩耍本设备。
- If the supply cord is damaged, it must be replaced by the manufacturer or its service agent or a similarly qualified person in order to avoid a hazard.
如果电源软线损坏，为避免危险，必须由制造厂商，其维修部或类似的专业人员更换。
- The product must be mounted on to the ceiling which is enough strong, If the ceiling is not enough strong it must be reinforced for it to be strong enough.
产品必须安装在足够坚固的天花板上，如果天花板不够坚固，则必须加固以使其足够坚固。

The following explanations must always be observed in order to prevent harm to users or other people and prevent damage to property.

为了避免给您及其它人造成伤害，这里我们列出了以下安全注意事项，请务必遵守，各种标志的含义请参照以下内容。





- The following displays are classified and explained to what extent harm or damage occurs when the display details are ignored and the unit in question is wrongly used.

无视或错误理解这些标志，会产生下列两种情况。

	Warning 警告	This indication means : Must be treated seriously that this may result in death or serious injury. 本标志所表示的内容为“可能造成人员重伤或伤亡”。
	Caution 注意	This indication means : Must be treated seriously that this may result in injury or physical damage. 本标志所表示的内容为“可能造成人身伤害和其它物品损害”。

- The types of details to be observed are classified and explained in the following illustrated displays.
(Below are the series of illustrated displays)

需要遵守的详情类型进行了分类，并在以下插图显示中进行了说明。（以下为插图显示系列）

		This type of pictorial symbol indicates a “Prohibited” action that must be avoided. 此標誌表示為禁止事項
		This type of pictorial symbol indicates a “Compulsory” action that must be performed. 此標誌表示強制事項

INSTALLATION CAUTIONS

安装注意事项



Warning 警告

- The product must be grounded.
必须接地。



Otherwise, it may cause electric shock when there is any trouble or electric leakage.
当出现故障或漏电时，可能会触电。

- Do not install the power switch in bathroom.
禁止将电源开关安装在浴室内。



Otherwise, it may cause a short circuit, thus resulting a fire.
否则可能会导致短路，导致火灾。

- Do not install the product as the method which is not approved in the instruction.
禁止使用本说明书指定以外的方法进行安装。



Otherwise, the product may fall down and it may cause injury.
否则产品可能会掉落，导致受伤。

- Do not operate the product other than the voltage in name plate.
禁止使用额定电压以外的电源。



Otherwise, it may damage the product or cause fire.
否则可能会导致损坏本产品，导致火灾。

- Do not install the fan out of the window and wall.
禁止将换气扇安装于窗外或墙壁外。



Otherwise, the product may get wet in the rain and cause short circuit.
否则产品可能会淋雨，导致短路。

- Please install an all-pole switch which the contact separation is more than 3 mm (all-pole switch).
安装时，须在供电线路中安装其触电开距不少于3 mm的全极断开装置(全极开关)。



Otherwise, it may cause a short circuit, thus resulting a fire.
否则可能会导致短路，导致火灾。

- Wiring is required to follow the local wiring regulations.
器具应按照国家布线规则进行安装。



Otherwise, it may cause fire.
否则可能会导致火灾。

- Installation should be done by authorized person.
The product should be installed firmly.
必须由专业人员进行安装，必须牢固地安装产品。



Otherwise, the product any fall down and it may cause injury.
否则产品可能会掉落，导致受伤。

INSTALLATION CAUTIONS

安装注意事项



Caution 注意

- The special-purpose or dedicated parts, such as mounting fixtures, must be used if such parts are provided.

有安装五金件等专用零部件时，应使用专用零部件。



Otherwise, the product may fall down and it may cause injury.

否则产品可能会掉落，导致受伤。

- The product must be installed tightly.
机体安装必须牢固。



Otherwise, it may injure person caused by product's falling off.

否则机体可能会掉落，导致受伤。

- Do avoid the back-flow of gas into the room from the open flue of flammable gas or other open-fire appliances.

必须避免气体从敞开的气道或其他明火设备回流进室内。



Otherwise, it may cause fire.

否则可能会导致火灾。

- Components must be installed tightly.

部品安装必须牢固。



Otherwise, it may injure person caused by product's falling off.

否则部品可能会掉落，导致受伤。

- The lowest surface of this product should be installed above 2.3 m from the floor after installation.

安装完成后产品最底面至地面的距离必须大于 2.3 m。



Avoiding any accident
防止意外

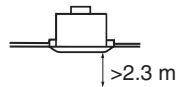

- Do not reconstruct this product.

禁止对本产品进行改造。



Otherwise, it may cause damage to the product or injury.

否则可能会导致产品损伤或人身伤害。

INSTALLATION REQUIREMENTS

安装要求

Please observe the following requirement. Otherwise, it may cause the product aging and breakdown.
请遵守以下安装要求事项，否则有可能会导导致机体老化或发生故障。

- Do not install the product where there is steam.

请勿安装在有蒸汽的场所。

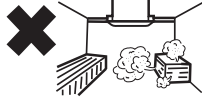

- Please set a square inspection hole of at least 45 cm.

请设置一个45 cm以上的方形点检口。

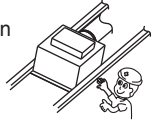

- Do not install the product in places with high temperature.

请勿安装在高温场所。

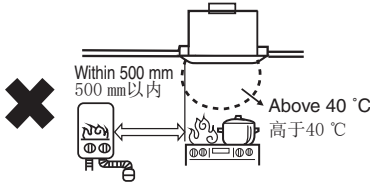

- Do not install the product where it is exposed to oil fumes.

请勿安装在油烟过多的场所。

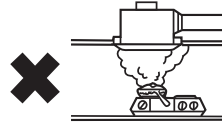

- Be sure to provide an appropriate opening for air intake.

请设置通风口。

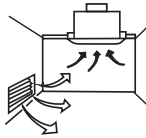

- Do not install onto slanting ceiling.

请勿安装在倾斜的天花板上。

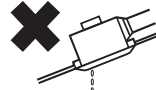

Prevent the water condensed in the duct pipe flow back into the body.

防止水通过安装管道倒流。

- Please don't carry out the following ductworks.

请勿执行以下管道系统。

Ductwork (1), (2), and (3) will increase the duct resistance, and ductwork (4) will cause turbulence and airflow collisions. These ductwork configurations may cause the product to operate under a condition where the inlet and/or outlet openings are almost blocked. This may not only increase levels of vibration and noise but also reduce the air volume and adversely affect the motor.

管道系统（1）、（2）和（3）会增大管道阻力，而管道系统（4）会造成湍流和气流碰撞。这些管道系统配置可能会造成产品在进气口和/或出口口几乎完全堵塞的情况下运行。这不仅会增大振动和噪音，还会降低风量，并对电机产生不利影响。

- (1) Bending extremely
严重弯曲



- (2) Bending repeatedly
反复弯曲

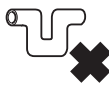

- (3) Making duct diameter too small
使管道直径太小

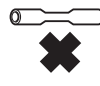

- (4) Bending very near to the adaptor
弯曲非常靠近接头

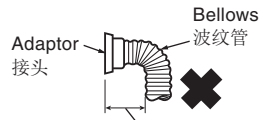

Separate 1m or more from the adaptor.
从接头分开1 m或以上。

- Do not install the product in the place with many dust.

请勿安装在灰尘较多的场所。



- The product is not provided with, all-pole switch and leakage protection switch. Please purchase them in market.
本产品没有附带电源全极开关和漏电保护开关，需用户另购。

SUPPLIED ACCESSORIES

包装附件清单

The following attachments are enclosed in the packing box of ventilating fan. Be sure to check if they are complete after unpacking, and if anything is missed, contact our After-Sales Service Center or the dealer.

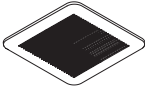
随换气扇产品包装箱有以下附件，开箱后请清点是否齐全，如不齐全，请于客户咨询服务中心或经销商联系。

No. 序号	Drawing 图样	Name and purpose 名称及用途	Quantity 数量
①		Self-tapping screw (use to fix the frame and adaptor assembly) 自攻螺丝 (用于固定框架和接头组合)	6
②		Louver 面罩	1
③		Installation and operating instructions 安装使用说明书	1

PARTS NAME AND DIMENSIONS

部件名称及尺寸

Unit: mm
单位: mm

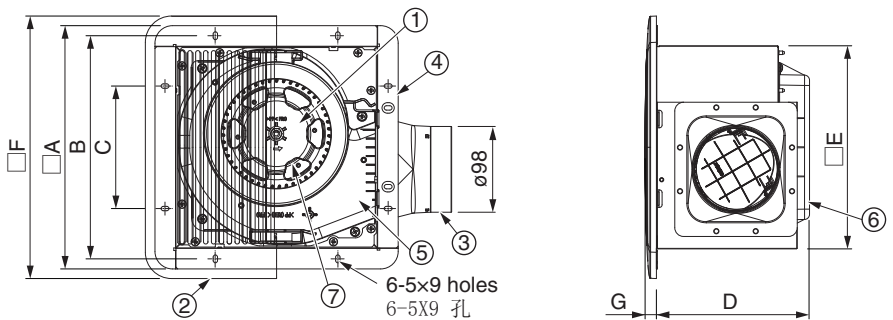

Model No. 型号	A	B	C	D	E	F	G	Duct size 管道尺寸	No. 序号	Part name 部件名	No. 序号	Part name 部件名
17CUH	214	194	84	164	170	230	13	ø100	①	Blade 扇叶	⑤	Casing 护套
24CUH 24CDH 24CHH	278	255	140	175	233	300	13	ø100	②	Louver 面罩	⑥	Wiring cover 接线罩
									③	Adaptor Assembly 接头组合	⑦	Motor 马达
									④	Fan body 机身		

HOW TO INSTALL

安装方法

1. Fan body installation Method 1 install with wooden joist.

1. 机体的安装 方法一 使用木龙骨安装

- ① Construct the wooden frame and attach it horizontally to the wooden joist. (Fig.1)
在木龙骨上水平搭建木框(图1)。

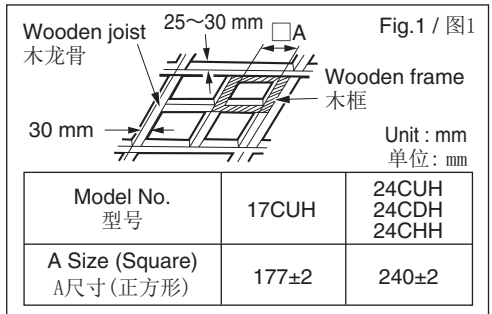

- The distance between the top of fan body and ceiling should not be less than 20 mm. (Fig.2)
注意应保持机体顶部和天花板的距离不小于20 mm (图2)。

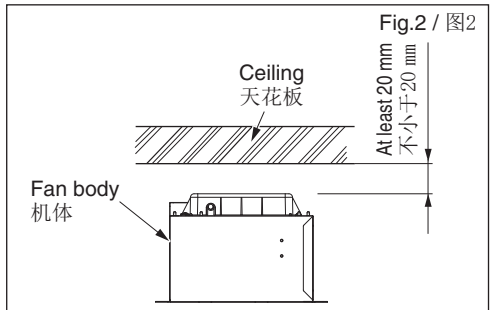

- ② Remove one hexagon screw that is fixed adaptor assembly and fan body, then remove the adaptor assembly. (Fig.3)

取下固定接头组合和机体的一颗螺丝，按图示方法拆下接头组合(图3)。

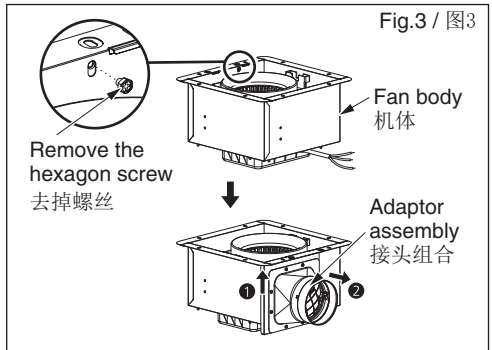

- ③ Fix the adaptor assembly on wooden frame with 2 self-tapping screws of $\Phi 4.2 \times 20$. (Fig.4)

按图示将接头组合紧靠木框固定，并用自攻螺丝 $\Phi 4.2 \times 20$ (2颗) 固定(图4)。

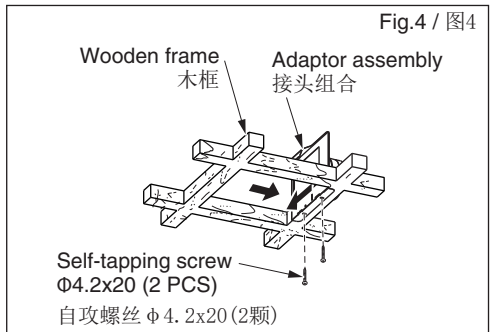

IMPORTANT

重要

Adaptor assembly should not fix at an angle.

固定接头组合时要注意不能和木框之间有角度



HOW TO INSTALL

安装方法

- ④ Connect the power cord (included earth) of fan body to lead wire in accordance with the wiring diagram. (Fig.5)

根据接线示意图，将机体电源线（包括地线）连接到供电电源线上(图5)。

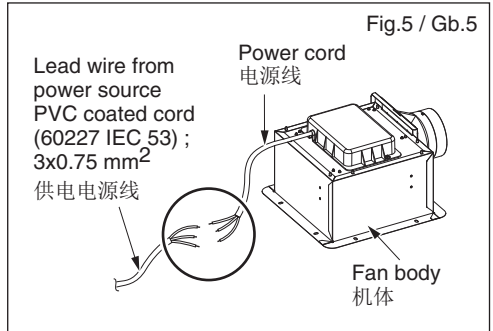

Notice 提示事项

Wiring should be firmly connected without any loose. Connection example. (Fig.6)

电源线连接处必须牢固，不能有松动。电源连接方法(图6)。

- It is required to use terminal (not supply) that complies IEC 60998. 要求使用符合IEC60998的接线端子座(另购)。
- Make sure all connections are fastened firmly after wiring is finished. 接线完成后，必须检查所有连接是否牢固。

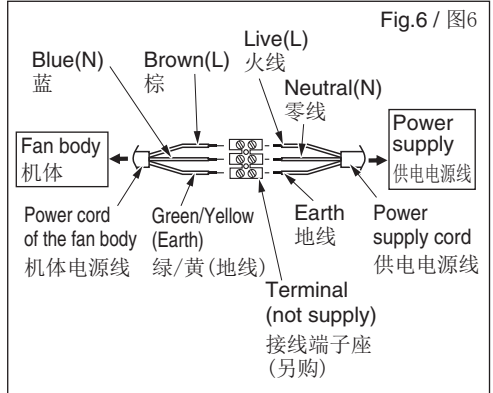

- ⑤ Make the power cord pass through the wooden frame, push the fan body into wooden frame, to fix the fan body and adaptor assembly. (Fig.7)

将电源线穿过木框，将机体推入木框，使机体与接头组合固定(图7)。

Notice 提示事项

- Power cord should reserve more than 400 mm, otherwise main body is hard to disassembly when maintenance. 电源线要有400 mm以上的预留，否则维修时机体难以拆卸。
- When the fan body is pushed into the wooden frame, be careful not to pinch the power cord. 机体推入木框时，请注意不要夹伤电源线。

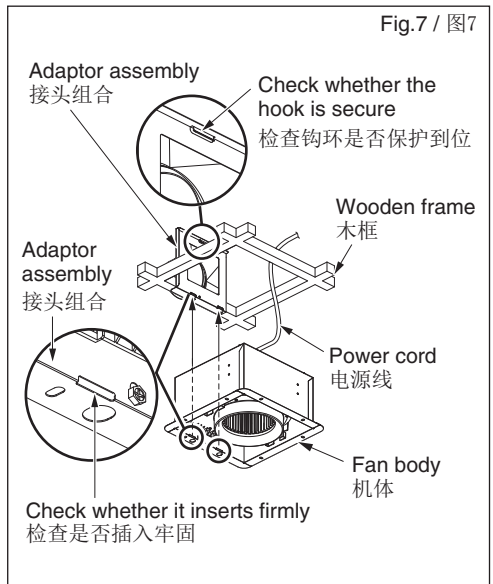

HOW TO INSTALL

安装方法

- ⑥ Fix fan body firmly with 4 self-tapping screws $\Phi 4.2 \times 20$. (Fig.8)

用自攻螺丝 $\Phi 4.2 \times 20$ (4颗) 将机体牢固的固定 (图8)。

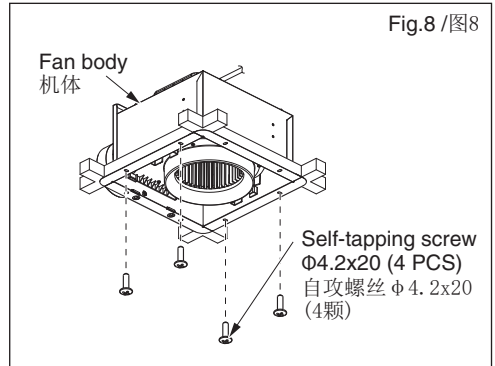

- ⑦ Fix adaptor assembly and fan body firmly with hexagon screw removed in step ②. (Fig.9)

用步骤②中拆下的螺丝将机体与接头组合牢固的固定起来 (图9)。

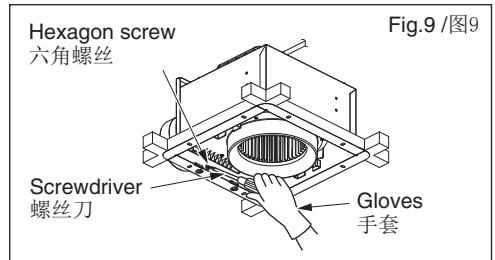

- After finishing installation, please confirm whether fan body and adaptor assembly are installed firmly.
安装完成后, 请确认机体与接头是否完全安装牢固。

- ⑧ Connect duct. ➡ refer to page 12

2. Connect duct

连接管道。→参考第12页

2. 管道连接

- ⑨ Install ceiling board in the range of 2~3 mm. (Fig.10)

安装天花板嵌板, 使法兰与天花板嵌板的间隙保持在2~3 mm范围内 (图10)。

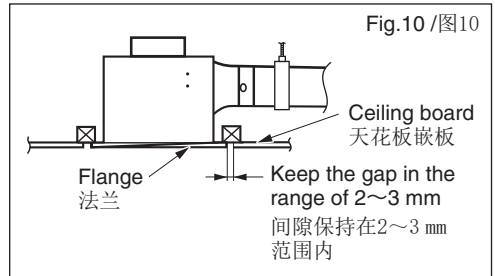

- ⑩ Insert the fixed spring of louver assembly into the groove, install the louver to the fan body. (Fig.11)

将面罩组合上的固定弹簧装入沟槽内, 将面罩装在机体上 (图11)。

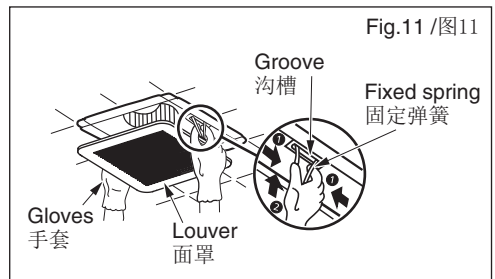

HOW TO INSTALL

安装方法

1. Fan body installation Method 2 install with anchor bolt

1. 机体的安装 方法二 使用地脚螺栓安装

- ① Secure the suspension bracket (not supply) with screws (not supply) (Fig.12).

用螺丝(另购)固定悬吊支架(另购)(图12)。

Notice 提示事项

The screw length is 8 mm.

自攻螺丝长度为8mm。

Suspension bracket must be made of metal with sufficient strength.

悬挂支架必须由具有足够强度的金属制成。

Model No. 型号	17CUH	24CUH 24CDH 24CHH
Net weight 净重 [kg]	1.7	2.1

- ② Install the fan body on the anchor bolt.

The distance between the top of fan body and ceiling should not be less than 20 mm. (Fig.13)
Anchor bolt (M8-M10, not supply) refer to the following form.

将机体安装在地脚螺栓(M8-M10另购)上。
注意应保持机体顶部和天花板的距离不小于20 mm (图13)。

- ③ Connect power cord. → refer to page 9
1. Fan body installation Method 1 install with wooden joist ④.

连接电源线→参考第9页

1. 机体的安装方法一 使用木龙骨安装 ④

- ④ Insert the fixed spring of louver assembly into the groove, install the louver to the fan body. (Fig.14)

将面罩组合上的固定弹簧装入沟槽内,进而安装在机体上(图14)。

Fig.12 /图12

Screw mounting position

螺丝安装位置

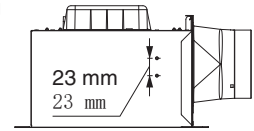

Tapping screw

ST4. 2×8

自攻螺丝

ST4. 2×8

Vibration-resistance rubber piece
(If necessary)

防震橡皮件

(如有必要)

Suspension bracket

悬吊支架

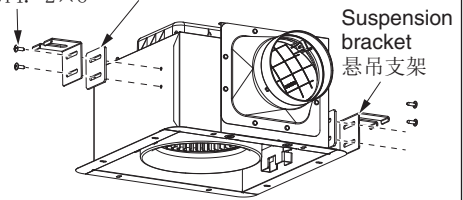

Fig.13 /图13

Washer
垫圈

Ceiling
天花板

At least 20 mm
不小于20 mm

Anchor bolt
地脚螺栓

Rubber Washer
No.1 and No.2
(If necessary)

防震垫圈

No. 1 and No. 2
(如有必要)

Suspension bracket
(not supply)

悬吊支架

(另购)

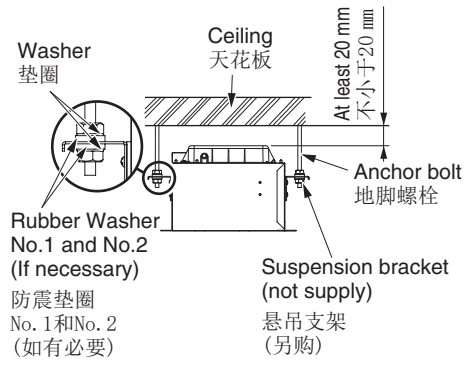

Fig.14 /图14

Groove
沟槽

Fixed spring
固定弹簧

Gloves
手套

Louver
面罩

Gloves
手套

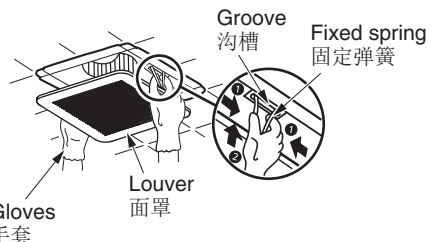

HOW TO INSTALL

安装方法

2. Connect duct

2. 管道连接

- ① Insert the duct (not supply) into the adaptor and secure it with adhesive tape (not supply) tightly. Suspend the duct from the ceiling so that no force is applied to the fan body. Install the duct horizontally with a gradient downwards to the outside. And the outlet of duct shall be located to avoid the rain ingress.

将管道(另购)装入接头组合上,然后用胶带(另购)粘紧密闭,防止漏风。将管道悬挂在天花板上,以防止外力施加于机体。管道水平向下倾斜的安装到外侧,其出口应设置在避免雨水进入的地方。



Notice 提示事项

The minimum diameter of the wall hole :
ø116 mm

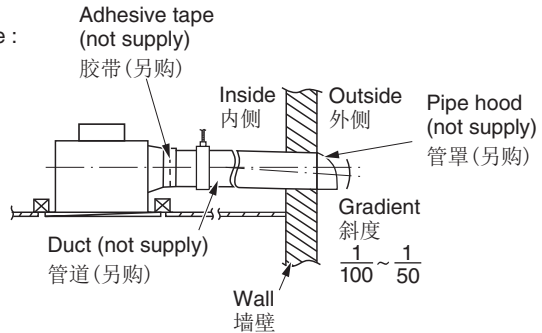
墙壁的最小开口尺寸为:116 mm。



- ② Insert the pipe hood or vent cap (optional accessories) on the outer wall. 将管盖或管罩(需要另外选购)安装到墙外。

Pipe hood 管罩	MCX100K 
Vent cap 管盖	VCX100K 

TEST RUN

试运转

- Please check whether all kinds of anomalies below happen after connecting power.
(When motion sensor is detected, fan runs)

在接通电源后，检查一下是否发生以下各种异常现象。
(当动作传感器感应到用户运动时，扇叶开始运转)

- Blades doesn't run properly.
扇叶不正常的运转。
- Blades is clockwise rotation.
扇叶顺时针旋转。
- Blades have abnormal vibration or noise.
发生不正常的声音或震动。

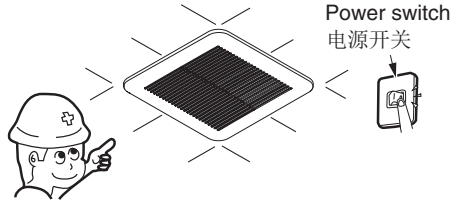

- If anomalies happen, please check whether the installation is right.

若出现异常现象，请检查是否安装正确。

MAINTENANCE

日常使用及维修



Warning 警告

- Do not directly spray this product with water and other liquids.
禁止用水及其他液体直接喷射、清洁本产品。



Otherwise, it may cause short circuit or electric shock.
否则可能会导致短路或触电。

- Do not let water flow into the motor.
禁止让水进入电动机。



Otherwise, it may damage the product or cause fire.
否则可能会损坏本产品或导致火灾。

- Once flammable gas leaks, do not start any function of this product.
当发生煤气泄漏时，禁止开启本产品的任何功能。



Otherwise, it may generate spark and this leads to explosion.
否则可能会产生电火花而引起爆炸。

- If you will not use this product any more, remove the product.
如果以后不打算再使用本产品，不得放置不管，而应予以拆除。



Otherwise, the product may fall down and it may cause injury.
万一掉落，可能会导致受伤。

MAINTENANCE

日常使用及维修



Warning 警告

- This product is applicable to living rooms, washrooms and other places where the humidity is not too high.

本产品须安装在起居室、卫生间等湿度不太高的场所。



Otherwise, it may lead to short circuit or electric shock.

否则可能会引起短路或触电。



Caution 注意

- Please wear the gloves when cleaning the product.

清洁时请戴上手套。



Otherwise, it may cause damage.

否则可能会导致受伤。



Cleaning Precautions 清洁提示事项

- Never immerse blade or other resin parts in hot water over 60 °C.

请勿把塑料部品浸入高于60 °C的水中。

- Never use petrol, benzene thinner or any other such chemicals for cleaning the product.

请勿使用汽油、苯、稀释剂或其他诸如此类的化学品擦拭换气扇。

MAINTENANCE

日常使用及维修

Clean product

清洁产品

① Remove the louver. (Fig.15)

拆下面罩(图15)。

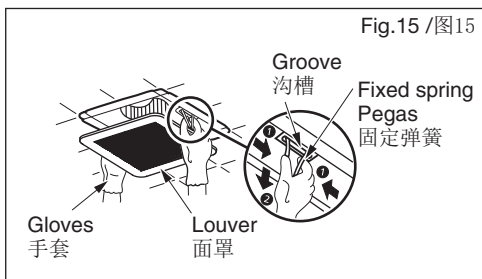

② Clean Louver. (Don't put into hot water. Use non-abrasive kitchen detergent, wipe dry with clean cloth) (Fig.16)

The Louver should be dry after cleaning.

用水冲洗面罩，干净的面罩请用柔软的干布擦干或风干(图16)。

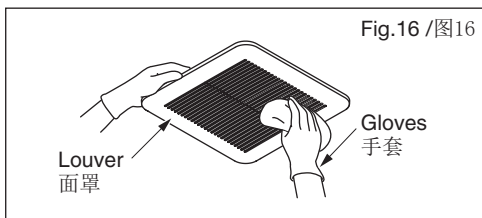

③ Clean the dirt of blades with vacuum cleaner. (Fig.17)

使用吸尘器清除扇叶上的污物(图17)。

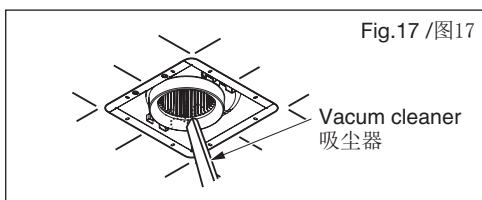

④ Wipe the dust off the fan body with a soft cloth moistened with kitchen detergent, and then clear it with a clean soft cloth. (Fig.18)

使用软布沾上厨房用洗涤剂后擦掉扇叶上的污物，再用干净软布擦净(图18)。

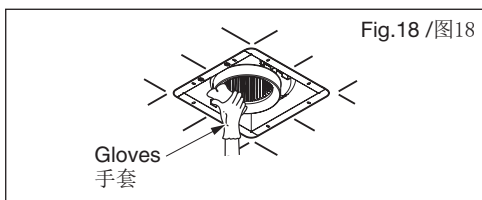

⑤ Finally, install the louver again. (Fig.19)

最后，重新装上面罩(图19)。

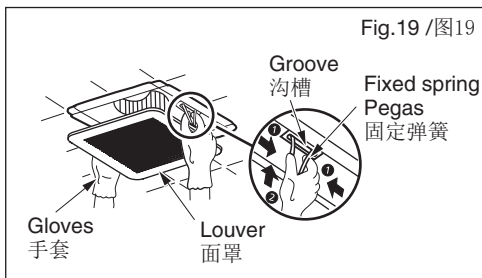

WIRING DIAGRAM

电气原理图

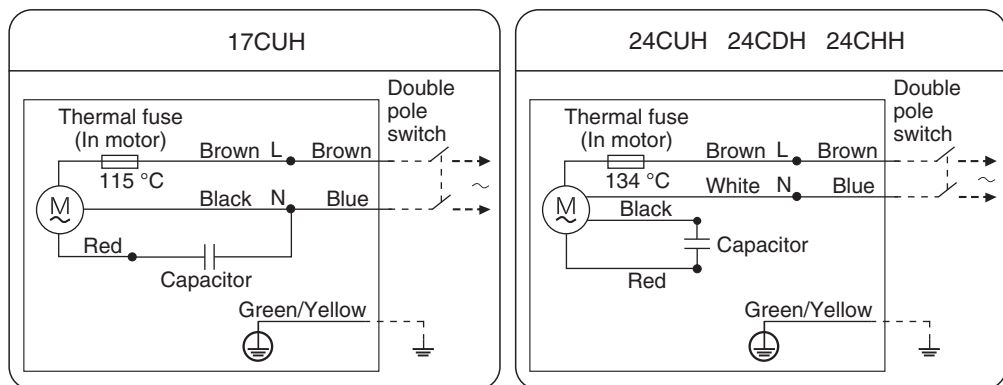

SPECIFICATIONS

规格

Model No. 型号	Voltage 电压 [V]	Frequency 频率 [Hz]	Power consumption 耗电量 [W]	Air delivery 风量 [m ³ /h]	Noise 噪音 [dB]	Static pressure 静压 [Pa]	Net weight 净重 [kg]
17CUH	220	50	7.5	85	23.0	110	1.7
	230	50	8.5	85	24.5	110	
	240	50	9.5	90	26.0	110	
	230	60	10.0	85	24.0	130	
24CUH	220	50	10.5	140	25.0	100	2.7
	230	50	11.0	150	26.0	100	
	240	50	12.0	160	27.0	100	
	230	60	13.5	150	26.5	130	
24CDH	220	50	13.5	170	28.5	100	2.7
	230	50	15.0	180	30.0	100	
	240	50	16.5	190	31.5	100	
	230	60	19.0	180	31.0	140	
24CHH	220	50	16.5	200	32.0	100	2.7
	230	50	18.0	210	34.0	100	
	240	50	19.5	210	35.0	110	
	230	60	22.5	200	34.0	135	

■ Insulation class B IP code :IPX2

■ B级绝缘 IP代码：IPX2

The above specification may be changed without further notice.

上述参数如有变动，恕不另行通知。

A series of 24 horizontal dotted lines spanning the width of the page, providing a template for writing.

A series of 20 horizontal dotted lines for writing.

A series of 20 horizontal dotted lines spanning the width of the page, intended for writing.

KDK Company, Division of PES

Head office: 4017, Takaki-cho, Kasugai, Aichi, Japan

17CUH4061A
V1222-1063