

Operating and Installation Instructions

Ceiling Fan

Model No. / No. Model / 型号

K14ZW

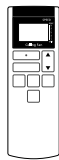
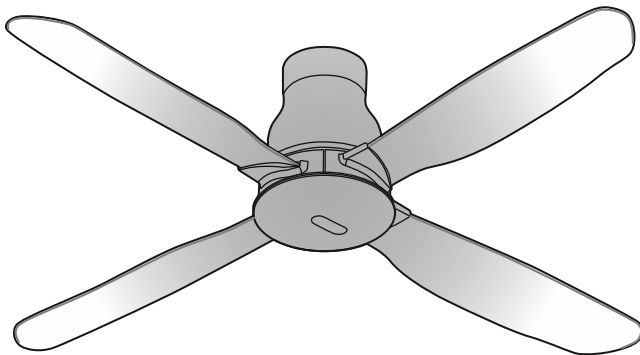

Operating and Installation Instructions

Ceiling Fan

Thank you for purchasing this KDK product.

Before operating this product, please read the instructions carefully, and save this manual for future use.

Contents

Safety precautions	2
Name of parts	5
How to install	6-11
How to use	12-19
Maintenance	Back cover
Specifications	Back cover

Panduan Penggunaan dan Pemasangan

Kipas Siling

Terima Kasih kerana membeli produk KDK.

Sebelum mengoperasikan produk ini, sila baca arahan dengan teliti dan simpan manual ini untuk kegunaan pada masa akan datang.

Kandungan

Pencegahan keselamatan	3
Nama bahagian	5
Cara pemasangan	6-11
Cara penggunaan	12-19
Penyelenggaraan	Muka belakang
Spesifikasi	Muka belakang

操作和安装指示

吊扇

感谢您购买 KDK 产品。

操作此产品前，请仔细阅读说明书，并保存本手册以作日后参考。

目录

安全注意事项	4
零件名称	5
如何安装	6-11
如何使用	12-19
维修	封底
规格	封底

Safety precautions

Always follow these instructions

To avoid the possibility of causing injury to users or damage to properties, please follow all the explanations written below.



This symbol denotes an action that is **COMPULSORY**.



This symbol denotes an action that is **PROHIBITED**.



WARNING

A state that may be caused by the mishandling of products, which, if not avoided, may lead to the possibility of death or serious injury of users.



WARNING



Follow strictly all the instructions given in this manual for installation. Electrical and installation work needs to be performed by a qualified individual.

Installation error can cause fire, electrical shock, injury or Ceiling Fan to drop.



This appliance is not intended for use by persons (including children) with reduced physical, sensory or mental capabilities, or lack of experience and knowledge, unless they have been given supervision or instruction concerning use of the appliance by a person responsible for their safety. Children should be supervised to ensure that they do not play with the appliance.



Switch off the power supply and wait until the Blades is fully static, before cleaning or doing any maintenance jobs.

Can cause injury or electrical shock if Ceiling Fan move suddenly.

Kindly refer to your authorized dealer for repairing or maintenance.



Tighten the Blade Screws firmly using a screwdriver. (250-300 N•cm)

Can cause injury if Blade drops.



Ensure that the ceiling hook can sustain more than 10 times the Ceiling Fan weight.

Can cause injury if Ceiling Fan drops.



Stop using the Ceiling Fan when any abnormality or failure occurs and turn "OFF" the Miniature Circuit Breaker (MCB).

Risk of smoke, fire, electrical shock or Ceiling Fan drops. Please contact your authorized dealer for repairing or maintenance.



Dismantle the broken or damaged Ceiling Fan.

Can cause injury if Ceiling Fan drops.



Do not install the Ceiling Fan at oily and dusty places.

Can cause fire or electrical shock due to short circuit.



Do not install the Ceiling Fan near flammable areas such as a gas cooker.

Can cause fire or electrical shock due to short circuit.



Do not install the Ceiling Fan near chemicals and alkali.

Can cause fire or electrical shock due to short circuit.



Do not damage the wire during installation e.g. deform due to heat, twist, bend, etc.

Can cause fire or electrical shock due to short circuit.



Do not use power supply other than rated voltage mentioned.

Overheating can cause electrical shock or fire.



Do not insert any metal items in the battery area with the Battery.

Can cause fire or electrical shock due to short circuit.



Do not hang onto the Ceiling Fan.

Can cause injury if Ceiling Fan drops.



Do not disassemble the Ceiling Fan unless stated by this manual.

Must use only supplied parts.

Can cause fire, electrical shock, injury or Ceiling Fan to drop.



Do not touch the Ceiling Fan while it is operating.

Can cause injury, damage or Ceiling Fan to drop.



Do not sprinkle water to Ceiling Fan or do not wet the Ceiling Fan.

Can cause fire or electrical shock due to short circuit.



CAUTION

A state that may be caused by the mishandling of products, which, if not avoided, may result in the injury of users or property damage.



CAUTION



To avoid the possibility of causing injury to users or damage to properties, please follow all the explanation written in this manual. The manufacturer will not be responsible for any accidents or injuries caused by defective, deficient installation or installation which does not follow the instruction manual.



Ceiling Fan must be mounted above 2.5 m from the floor and 1 m from the wall to the Blade.

Can cause unstable air flow and affect the Ceiling Fan to wobble.

Can cause injury if Ceiling Fan drops.

Refer to Step 2 - ① on page 13 for the measurement method.



After installation make sure the Ceiling Fan does not wobble extremely.

Can cause injury if Ceiling Fan drops.



Replace all the Blades if any of them breaks or cracks.

Can cause injury if Ceiling Fan drops due to wobbling.



Do not install the Ceiling Fan at a wet, high temperature and high humidity area such as shower room.

If an electrical current leakage occurs, it can cause electrical shock or fire easily.



This product is for in house use only. Do not install at a windy places.

Can cause rust, discolour, damage or injury.



Do not install at places where there is high vibration and impact.

Can cause injury if Ceiling Fan drops.



Avoid fixing inside dome ceiling.

Can cause unstable air flow and affect the Ceiling Fan to wobble.

Can cause injury if Ceiling Fan drops.



Do not expose yourself continuously to direct wind from the Ceiling Fan.

It may cause discomfort.



Wipe away dirt with a clean soft cloth, ordinary soap and water to keep the Ceiling Fan clean. Do not use solvents (gasoline, petroleum, thinner, benzene, alcohol, cleaning powder, alkaline detergent) or any other chemicals.

Can cause plastic part deformation or metal corrosion.

Can cause injury if parts drop.



Ensure that the Ceiling Hook ("J" Hook) or ("U" Hook) is not loosen. Tighten the Bolt and Nut of the Pulley Set Plate firmly using a torque wrench. (1500-1800 N•cm)

Can cause injury if Ceiling Fan drops due to wobbling.

Refer to Step 2 on page 7 for the installation method.

Pencegahan keselamatan

Sentiasa mengikut arahan berikut

Untuk mengelakkan kemungkinan berlakunya kecederaan kepada pengguna atau kerosakan harta benda, sila patuhi semua penerangan yang dinyatakan di bawah.

	Simbol ini menunjukkan perbuatan yang WAJIB DILAKUKAN.		Simbol ini menunjukkan perbuatan yang DILARANG.
---	--	---	---

	AMARAN	Keadaan yang mungkin disebabkan oleh kecuai dalam mengendalikan produk, yang mana, jika tidak dielakkan, boleh mengakibatkan kematian atau kecederaan parah kepada pengguna.
---	---------------	--

	AMARAN
---	---------------

	Sila rujuk kepada semua arahan yang diberikan dalam panduan ini untuk pemasangan. Kerja elektrik dan kerja pemasangan mesti dilakukan oleh orang yang bertauliah. Kesilapan pemasangan boleh menyebabkan kebakaran, kejutan elektrik, kipas siling terjatuh atau kecederaan.
---	--

	Peralatan ini tidak direka untuk digunakan oleh individu (termasuk kanak-kanak) yang mempunyai kecacatan anggota, deria atau kebolehan mental, atau kurang pengalaman dan pengetahuan, melainkan mereka telah diberikan pemerhatian atau panduan mengenai penggunaan peralatan ini oleh individu yang bertanggungjawab mengenai keselamatan mereka. Kanak-kanak mestilah diberi pemerhatian untuk memastikan mereka tidak bermain dengan peralatan ini.
---	--

	Putuskan bekalan kuasa dan tunggu sehingga Bilah Kipas berhenti sepenuhnya, sebelum membersihkan atau membuat kerja penyelenggaraan. Boleh menyebabkan kecederaan atau kejutan elektrik jika Kipas Siling bergerak secara tiba-tiba. Sila rujuk pada wakil penjual anda untuk membaiki atau penyelenggaraan.
---	---

	Ketatkan Skru Bilah Kipas dengan kukuh menggunakan pemutar skru. (250-300 N•cm) Boleh menyebabkan kecederaan jika Bilah Kipas terjatuh.
--	---

	Pastikan cangkuk siling boleh menanggung beban 10 kali ganda berat Kipas Siling. Boleh menyebabkan kecederaan jika Kipas Siling terjatuh.
---	---

	Berhenti menggunakan Kipas Siling apabila mendapati apa-apa keganjilan atau kegagalan berlaku dan putar Pemutus Litar Miniatur (MCB) kepada "OFF". Risiko asap, kebakaran, kejutan elektrik atau Kipas Siling terjatuh. Sila hubungi wakil penjual anda untuk membaiki atau penyelenggaraan.
---	---

	Tanggalkan Kipas Siling yang patah atau yang mengalami kerosakan. Boleh menyebabkan kecederaan jika Kipas Siling terjatuh.
---	--

	Elakkan memasang Kipas Siling di tempat berminyak dan berhabuk. Boleh menyebabkan kebakaran, atau kejutan elektrik akibat litar pintas.
---	---

	Jangan pasang Kipas Siling di kawasan yang berhampiran dengan barang mudah terbakar seperti dapur gas. Boleh menyebabkan kebakaran, atau kejutan elektrik akibat litar pintas.
---	--

	Jangan pasang Kipas Siling berhampiran dengan bahan kimia dan alkali. Boleh menyebabkan kebakaran, atau kejutan elektrik akibat litar pintas.
---	---

	Elakkan kerosakan pada dawai semasa pemasangan. contohnya, dawai berubah bentuk kerana panas, terpulas, bengkok, dsb. Boleh menyebabkan kebakaran, atau kejutan elektrik akibat litar pintas.
---	---

	Jangan gunakan bekalan kuasa selain dari voltan yang telah ditetapkan. Pemanasan yang terlampau boleh menyebabkan kejutan elektrik atau kebakaran.
---	--

	Jangan masukkan sebarang logam kedalam ruang bateri bersama-sama Bateri. Boleh menyebabkan kebakaran, atau kejutan elektrik akibat litar pintas.
---	--

	Jangan bergantung pada Kipas Siling. Boleh menyebabkan kecederaan jika Kipas Siling terjatuh.
---	---

	Jangan buka sebarang bahagian-bahagian Kipas Siling melainkan dinyatakan di dalam panduan ini. Hendaklah menggunakan bahagian-bahagian yang dibekalkan sahaja. Boleh menyebabkan kebakaran, kejutan elektrik, kecederaan atau Kipas Siling terjatuh.
---	--

	Jangan sentuh Kipas Siling ketika ia sedang beroperasi. Boleh menyebabkan kecederaan, kerosakan atau Kipas Siling terjatuh.
---	---

	Jangan percikkan air ke Kipas Siling atau, jangan basahkan Kipas Siling. Boleh menyebabkan kebakaran, atau kejutan elektrik akibat litar pintas.
---	--

	AWAS	Keadaan yang mungkin disebabkan oleh salah pengendalian produk yang jika tidak dielakkan, boleh mengakibatkan kecederaan kepada pengguna atau kerosakan harta benda.
---	-------------	--

	AWAS
---	-------------

	Untuk mengelakkan kemungkinan berlaku kecederaan kepada pengguna atau kerosakan harta benda, sila patuhi semua arahan yang dinyatakan dalam panduan ini. Pengilang tidak akan bertanggungjawab sekiranya berlaku sebarang kemalangan atau kecederaan yang disebabkan oleh kesilapan pemasangan atau pemasangan yang tidak mengikut buku panduan.
---	---

	Kipas Siling mesti dipasang lebih daripada 2.5 m dari lantai dan jarak 1 m dari dinding ke Bilah Kipas. Boleh menyebabkan ketidakstabilan aliran angin dan mengakibatkan Kipas Siling bergoyang. Boleh menyebabkan kecederaan jika Kipas Siling terjatuh. Rujuk Langkah 2 - ① pada muka surat 13 untuk kaedah pengukuran.
---	---

	Selepas pemasangan, pastikan Kipas Siling tidak terlampau goyang. Boleh menyebabkan kecederaan jika Kipas Siling terjatuh.
---	--

	Gantikan kesemua Bilah Kipas jika salah satu daripadanya patah atau retak. Boleh menyebabkan kecederaan jika Bilah Kipas terjatuh akibat goyangan.
---	--

	Jangan pasang di tempat yang basah, bersuhu tinggi dan berkelembapan tinggi seperti di dalam bilik air. Jika terdapat kebocoran arus elektrik, kejutan elektrik atau kebakaran mudah berlaku.
---	---

	Produk ini adalah untuk kegunaan dalam rumah sahaja. Jangan pasang di tempat yang berangin. Boleh menyebabkan karat, warna luntur, kerosakan atau kecederaan.
---	---

	Jangan pasang di tempat yang terdapat getaran dan hentakan tinggi. Boleh menyebabkan kecederaan jika Kipas Siling terjatuh.
---	---

	Elakkan memasang di siling berbentuk kubah. Boleh menyebabkan aliran udara yang tidak stabil dan mempengaruhi Kipas Siling untuk bergoyang. Boleh menyebabkan kecederaan jika Kipas Siling terjatuh.
---	---

	Elakkan pendedahan angin pada Kipas Siling secara berterusan. Ia boleh menyebabkan ketidakselesaan.
---	---

	Lapkan kotoran dengan menggunakan kain yang bersih dan lembut, sabun biasa dan air untuk mengekalkan kebersihan kipas. Jangan gunakan pelarut (gasolin, petrol, pencair, benzin, alkohol, serbuk pencuci, detergen alkali) atau bahan kimia lain. Boleh menyebabkan kerosakan bahagian plastik atau besi berkarat. Boleh menyebabkan kecederaan jika komponen terjatuh.
---	--

	Pastikan Cangkuk Siling (Cangkuk "J") atau (Cangkuk "U") tidak longgar. Ketatkan Bolt dan Nut pada Plat Takal menggunakan sepana kilas. (1500-1800 N•cm) Boleh menyebabkan kecederaan jika Bilah Kipas terjatuh akibat goyangan. Rujuk Langkah 2 pada muka surat 7 untuk kaedah pemasangan.
---	--

安全注意事项

务必遵循以下指示

为避免导致用户受伤或财物损坏的可能性，请遵守以下所述的所有指示。

 此符号表示有关行为是强制性的。	 此符号表示有关行为是被禁止的。
---	---

 警告	错误操作产品造成情形，若不可避免可能导致用户死亡或严重受伤。
---	--------------------------------

 警告	
---	--

-  安装时请严格地遵守本手册内所给的所有指示。电线配线和安装工作必须由能胜任的人员进行。安装错误可以导致火灾、触电、受伤或吊扇掉落。
-  除非由安全监护人就本产品进行监督或指导，否则身体、感官或智力有功能障碍者，或者缺乏相关经验和知识的人士（包括儿童）请勿使用本产品。为了确保年幼的小孩不玩此电器，他们该受到监督。
-  清扫或进行任何维修工作前，关闭所有电源并等待扇翼完全静止。
若吊扇突然移位，可以导致受伤或触电。
请向您的经销商咨询有关修理或维修的详情。
-  使用螺丝起子将扇翼螺丝锁紧。(250-300 N•cm)
若扇翼掉落会导致受伤。
-  确定天花板钩子可以承受超过吊扇的 10 倍重量。
若吊扇掉落会导致受伤。
-  当发生任何异常或故障时，停止使用吊扇并关闭“OFF”微型断路器（MCB）。
可能有烟雾、火灾、触电或吊扇掉落的风险。
请向您的经销商咨询有关修理或维修的详情。
-  拆除破损或损坏了的吊扇。
若吊扇掉落会导致受伤。
-  避免将吊扇安装在油腻及多尘的地方。
这可以导致火灾或电源短路而触电。
-  切勿安装在煤气灶等易燃地区附近。
这可以导致火灾或电源短路而触电。
-  切勿将吊扇安装在化学品和碱性物附近。
这可以导致火灾或电源短路而触电。
-  避免在安装时损坏电线，例如因热量、扭曲、弯曲造成的变形等等。
这可以导致火灾或电源短路而触电。
-  切勿使用本文指定的额定电压以外的电源。
过热可导致触电或火灾。
-  切勿把金属物体与电池一起放入电池置放处。
这可以导致火灾或电源短路而触电。
-  切勿悬挂在吊扇上。
若吊扇掉落会导致受伤。
-  请勿拆除吊扇，除非此说明书指示。
务必只使用附带的零件。
可以导致火灾、触电、受伤或吊扇掉落。
-  请勿在吊扇正在操作的时候触摸吊扇。
可以导致受伤、损坏或吊扇掉落。
-  切勿向吊扇洒水。或者，切勿弄湿吊扇。
这可以导致火灾或电源短路而触电。

 注意	错误操作产品造成情形，若不可避免可能导致用户受伤或财物损失。
---	--------------------------------

 注意	
---	--

-  为避免导致用户受伤或财物损坏的可能性，请遵守本说明书内的所有指示。制造商对任何因不正确的安装或不按照说明书指示的安装所造成的任何意外和损伤将不负任何责任。
-  吊扇必须挂在离地面至少 2.5 米以上的高度，而扇翼必须离开墙壁 1 米以上。
可以导致不稳定气流和吊扇摇晃。
若吊扇掉落会导致受伤。
请参阅步骤 2-①，第 13 页的测量方法。
-  安装完毕后，请确保吊扇不会过度摇晃。
若吊扇掉落会导致受伤。
-  若任何一片扇翼断了或出现裂痕，请更换所有扇翼。
如果发生摇晃，可能导致吊扇掉落并造成损伤。
-  切勿将吊扇安装于潮湿、高温及高湿度的地方，例如浴室。
若发生漏电，这很容易会导致触电或火灾。
-  本产品只供室内使用。切勿安装在多风的地方。
可导致生锈、退色、损坏或受伤。
-  切勿安装在高振动强度和高冲击强度的地方。
若吊扇掉落会导致受伤。
-  避免安装在圆顶天花板。
可以导致不稳定气流和吊扇摇晃。
若吊扇掉落会导致受伤。
-  避免长时间让吊扇直接吹着您。
这可能会导致不适。
-  用干净的软布、普通肥皂和水抹去污渍以保持吊扇的清洁。切勿使用溶剂（汽油、石油、稀释剂、苯、酒精、去污粉和碱性洗涤剂）或任何其他化学物品。
这可导致塑料部件变形或金属腐蚀。
若零件掉落，则可能导致受伤。
-  确保天花板钩（“J”钩）或（“U”钩）已拧紧。
用随附的螺栓和螺帽将滑轮装置盘拧紧。
(1500-1800 N•cm)
如果发生摇晃，可能导致吊扇掉落并造成损伤。
请参阅步骤 2，第 7 页的安装指示。

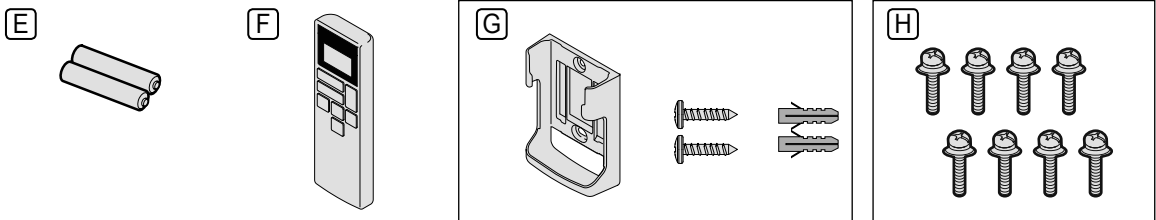
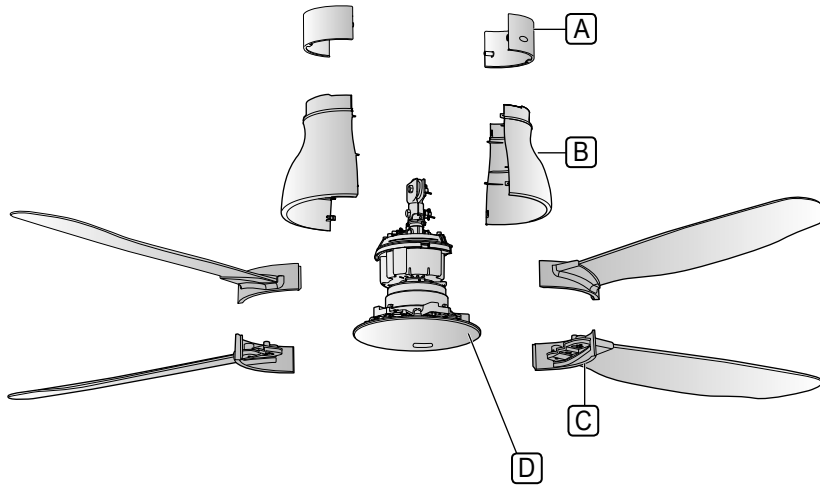

Parts	piece(s)	Bahagian-bahagian	unit	零件	件
A Upper Canopy	2	A Sengkuap Atas	2	A 上罩盖	2
B Lower canopy	2	B Sengkuap Bawah	2	B 下罩盖	2
C Blade Assembly	4	C Pemasangan Bilah Kipas	4	C 扇翼组件	4
D Motor Unit	1	D Unit Motor	1	D 发动机组件	1
E Batteries AAA / R03 / LR03	2	E Bateri AAA / R03 / LR03	2	E 电池 AAA / R03 / LR03	2
F Remote Control	1	F Alat Kawalan Jauh	1	F 遥控器	1
G Remote Control Holder Set	1	G Set Pemegang Alat Kawalan Jauh	1	G 遥控器固定器组件	1
H Blade Screws	8	H Skru Bilah Kipas	8	H 扇翼螺丝	8

Attention:
 • Do not place the Ceiling Fan directly on the floor.
 Refer to Step 1 (page 6) for the installation method.
 Can cause scratches to the product.

Note:
 • The illustrations in this manual are for explanation purposes only and may differ from the actual unit.

Perhatian:
 • Jangan letak Kipas Siling di atas lantai. Rujuk Langkah 1 (muka surat 6) untuk kaedah pemasangan. Boleh menyebabkan kesan calar pada produk.

Nota:
 • Ilustrasi pada buku panduan ini adalah untuk tujuan penerangan sahaja dan mungkin berbeza dari unit asal.

留意:
 • 切勿把吊扇直接放置在地上。请参阅步骤 1 (第 6 页) 的安装方法。这可导致产品被刮花。

备注:
 • 本手册中的插图仅用于说明，可能与实际组件有所不同。

WARNING

! Do not use modified parts other than original supplied parts. Can cause injury if the Ceiling Fan drops.

AMARAN

! Jangan guna bahagian yang telah diubahsuai selain daripada bahagian yang dibekalkan. Boleh menyebabkan kecederaan jika Kipas Siling terjatuh.

警告

! 除了所提供的原厂零件，不可使用其他经修改的零件。若吊扇掉落会导致受伤。

1

■ Install the Blades

- ① Put the Motor Unit **D** on the round portion (INSTALLATION AREA **a**) of the PACK B **b** as shown to assemble the Blade Assembly **C**.
- ② Assemble the Blade Assembly **C** towards the Safety Hook **a**.
- ③ Pull the Blade Assembly **C** in the direction as shown to lock the Blade.
- ④ Tighten the Blades Assembly firmly with the Screws **H** provided (Taken from the Part Set). Use 2 screws for one Blade Assembly. For reference, tightening torque is 250-300 N•cm. Ensure the Blade Assembly screw hole is center with the Diecast Cover assembly screw hole. Hold the Blade Assembly during installation.

■ Memasang Bilah Kipas

- ① Letakkan Unit Motor **D** di atas bahagian bulatan (INSTALLATION AREA **a**) pada PACK B **b** untuk Pemasangan Bilah Kipas **C** seperti yang ditunjukkan.
- ② Pemasangan Bilah Kipas **C** ke arah Cangkuk Keselamatan **a**.
- ③ Tarik Pemasangan Bilah Kipas **C** mengikut arah dalam rajah yang ditunjukkan untuk mengunci Bilah Kipas.
- ④ Ketatkan Pemasangan Bilah Kipas menggunakan Skru **H** yang diberi (Diambil daripada Set Komponen). Gunakan 2 batang skru untuk satu Pemasangan Bilah Kipas. Sebagai rujukan, kilas pengetatan adalah 250-300 N•cm. Pastikan lubang skru di Pemasangan Bilah Kipas selari dengan lubang skru pada Penutup Acuan. Pegang Pemasangan Bilah Kipas semasa memasang.

■ 安装扇翼

- ① 如图所示将发动机组件 **D** 置于 PACK B **b** 的圆形部分 (INSTALLATION AREA **a**) 以安装扇翼组件 **C**。
- ② 将扇翼组件 **C** 装入扇翼安全钩 **a**。
- ③ 如图所示方向拉动以锁定扇翼组件 **C**。
- ④ 用随附的螺丝 **H** 固定好扇翼组件 (从零件组中取出)。每片扇翼组件使用 2 枚螺丝。仅供参考的拧紧转矩为 250-300 N•cm。确保扇叶组件的螺丝孔与压铸盖的螺丝孔中心对齐。安装时, 务必托着扇叶组件

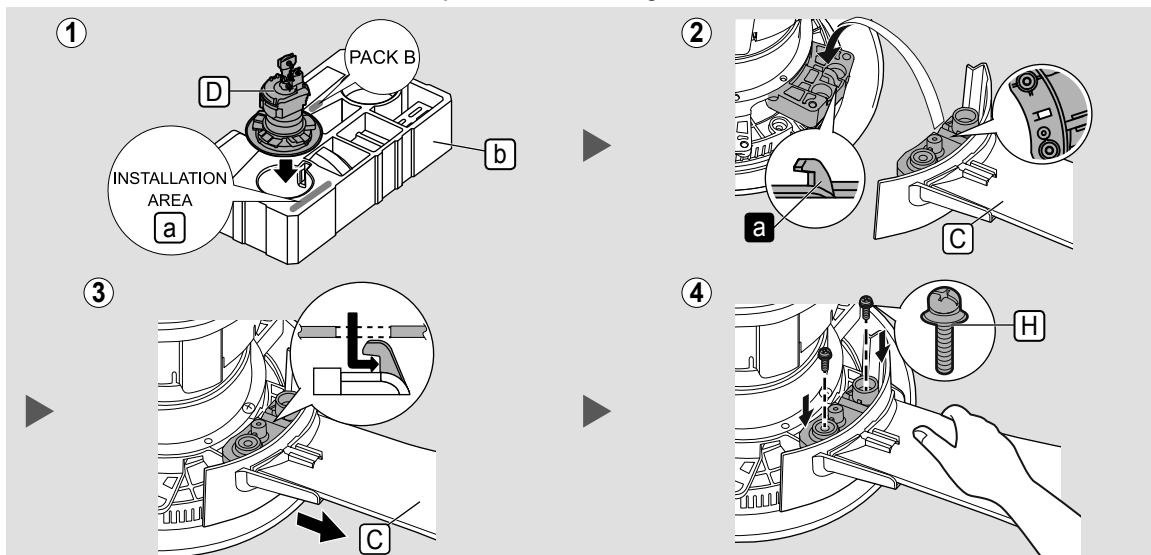

<p>WARNING</p> <p> Tighten the Blade Screws firmly using a screw driver. (250-300 N•cm) Can cause injury if the Blade drops.</p>	<p>AMARAN</p> <p> Ketatkan Skru Bilah Kipas dengan menggunakan pemutar skru. (250-300 N•cm) Boleh menyebabkan kecederaan jika Bilah Kipas terjatuh.</p>	<p>警告</p> <p> 用螺丝起子将扇翼螺丝锁紧。(250-300 N•cm) 若扇翼掉落会导致受伤。</p>
<p>CAUTION</p> <p> The Blade must be fixed correctly. Can cause no air flow. Can cause injury if the Blade drops.</p>	<p>AWAS</p> <p> Pemasangan Bilah Kipas mestilah dipasang dengan betul. Boleh menyebabkan tiada arus angin. Boleh menyebabkan kecederaan jika Bilah Kipas terjatuh.</p>	<p>注意</p> <p> 必须正确上紧扇翼。 这会导致没有气流。 若扇翼掉落会导致受伤。</p>

<p><input checked="" type="checkbox"/> Check point after installation</p> <p><input type="checkbox"/> The Blade Screws (8 pieces) fixing the Blades are securely tightened.</p>	<p><input checked="" type="checkbox"/> Pemeriksaan selepas pemasangan</p> <p><input type="checkbox"/> Pemasangan Bilah Kipas dengan Skru Bilah Kipas (8 batang) diskrus ketat dengan selamat.</p>	<p><input checked="" type="checkbox"/> 组装后的检验点</p> <p><input type="checkbox"/> 确定用作锁定扇翼组件的螺丝 (8 枚) 已被锁紧。</p>
---	---	--

■ Install to ceiling

- ① Remove the supplied Bolt **b**, Nut **c**, Cotter Pin **d** and Pulley **e**.
- ② Ensure that the Ceiling Hook ("J" hook **c**) or ("U" hook **d**) is not loosen. For reference, the Ceiling Hook ("J" hook **c**) or ("U" hook **d**) can sustain 20 N.
- ③ Place Pulley **e** on to the Ceiling Hook **c**.
- ④ Tighten the Pulley Set Plate **f** firmly with the Bolt **b** and Nut **c** provided. For reference, tightening torque is 1500-1800 N•cm.
 - Cotter Pin **d** must fix into Bolt **b** and bent.

■ Memasang ke siling

- ① Tanggalkan Bolt **b**, Nut **c**, Cemat Baji **d** dan Takal **e** yang dibekalkan.
- ② Pastikan Cangkuk Siling (Cangkuk "J" **c**) atau (Cangkuk "U" **d**) tidak longgar. Sebagai rujukan, Cangkuk Siling (Cangkuk "J" **c**) atau (Cangkuk "U" **d**) boleh menanggung beban 20 N.
- ③ Pasang Takal **e** pada Cangkuk Siling **c**.
- ④ Ketatkan Bolt **b** dan Nut **c** pada Plat Takal **f** menggunakan sepina kilas. Sebagai rujukan, kilas pengetatan adalah 1500-1800 N•cm.
 - Cemat Baji **d** mesti dipasang pada Bolt **b** dan dibengkokkan.

■ 安装至天花板

- ① 将配备的螺栓 **b**、螺帽 **c**、开口销 **d** 及滑轮 **e** 拆除。
- ② 确保天花板钩 ("J" 钩 **c**) 或 ("U" 钩 **d**) 已拧紧。仅供参考天花板钩 ("J" 钩 **c**) 或 ("U" 钩 **d**) 能够支撑 20 N。
- ③ 将滑轮 **e** 置于天花板钩子 **c**。
- ④ 用随附的螺栓 **b** 和螺帽 **c** 将滑轮装置盘 **f** 拧紧。仅供参考的拧紧转矩为 1500-1800 N•cm。
 - 开口销 **d** 必须插入螺栓 **b** 然后折弯。

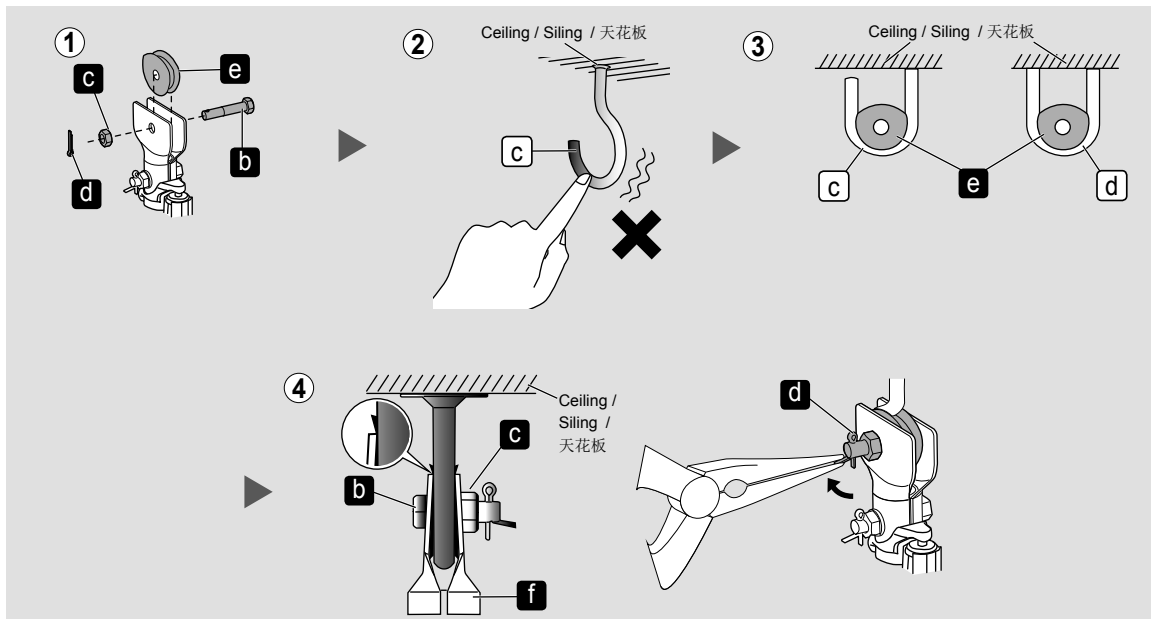

■ Note:

- In case "U" hook **d** is being used, installation method is the same.

■ Nota:

- Walaupun cangkuk jenis "U" **d** digunakan, kaedah pemasangan masih sama.

■ 备注:

- 如果 "U" 形钩子 **d** 被使用, 安装方法是相同的。

⑤ Remove the Safety Wire Screw **g** from the Pipe.

⑥ Arrange and tie the Safety Wire **h** as shown.

- Slot in the Safety Wire **h** from the side of opening of the Switch Lever **e**.
- Firmly screw the Safety Wire **h** with Safety Wire Screw **g** onto the Pipe.

⑤ Tanggalkan Skru Wayar Keselamatan **g** dari Paip.

⑥ Susun dan ikat Wayar Keselamatan **h** seperti yang ditunjukkan.

- Masukkan Wayar Keselamatan **h** pada bukaan Tuil Suis **e**.
- Ketatkan skru pada Wayar Keselamatan **h** dengan Skru Wayar Keselamatan **g** pada Paip.

⑤ 从导管拆除保险线螺丝 **g**。

⑥ 如图所示排列及系绑保险线 **h**。

- 输入保险线 **h** 于开关杆 **e** 的开口侧边插入槽中。
- 以保险线螺丝 **g** 锁紧保险线 **h** 至导管。

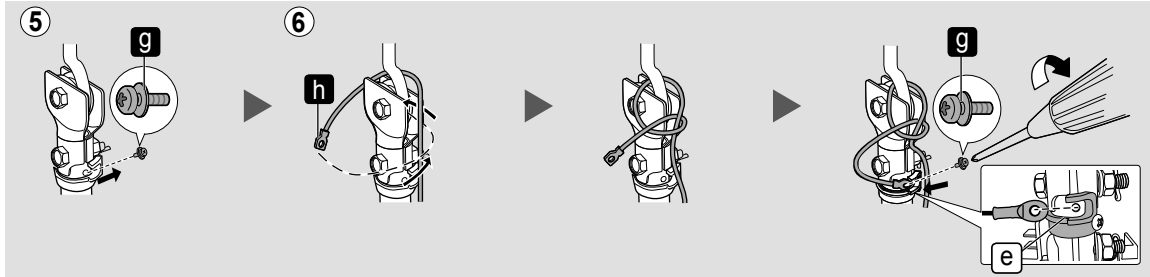

! WARNING

! Ensure that the Ceiling Hook can sustain more than 10 times the Ceiling Fan weight. Safety Wire must be fixed correctly to the Pipe. Can cause injury if the Ceiling Fan drops.

! AMARAN

! Pastikan Cangkuk Siling boleh menanggung beban 10 kali ganda berat Kipas Siling. Wayar Keselamatan mesti dipasang dengan betul pada Paip. Boleh menyebabkan kecederaan jika Kipas Siling terjatuh.

! 警告

! 确定天花板钩子可以承受超过吊扇的 10 倍重量。保险线必须正确地安装至导管。若吊扇掉落会导致受伤。

✓ Check point after installation

- Make sure Bolt and Nut are firmly tightened and Cotter Pin is inserted and bent for safety reason.
- Make sure Ceiling Fan is securely fixed on Ceiling Hook and Ceiling Fan not slanting after installation.
- The Safety Wire is looped to the Ceiling Hook and securely fixed to the Pipe.

✓ Pemeriksaan selepas pemasangan

- Untuk langkah keselamatan, pastikan semua Bolt dan Nut diketatkan dan Cermat Baji dimasukkan dan dibengkokkan.
- Pastikan Kipas Siling dipasang dalam keadaan selamat pada Cangkuk Siling dan Kipas Siling tidak senget selepas pemasangan.
- Wayar Keselamatan diililit pada Cangkuk Siling dan diskrus pada Paip.

✓ 组装后的检验点

- 确保所有螺栓和螺帽均已拧紧，且为了安全的考量，将开尾销插入并拧紧。
- 确保吊扇牢牢固定在扇钩里，而安装后吊扇不会倾斜。
- 保险丝被环到天花板钩和牢固地固定在管道上。

3

■ Wiring instruction

Connect the house's supply wire **f** to the terminal **i** according to the diagram shown.

- Recommended wire stripping length is 7 ~ 8 mm.

■ Panduan pendawaian

Sambungkan wayar bekalan kuasa rumah **f** kepada terminal **i** seperti panduan pendawaian yang ditunjukkan.

- Panjang pelucutan wayar yang disyorkan adalah 7 ~ 8 mm.

■ 配线指示

如图所示将房子的电源线 **f** 连接到终端 **i**。

- 建议剥线长度为 7 ~ 8 mm。

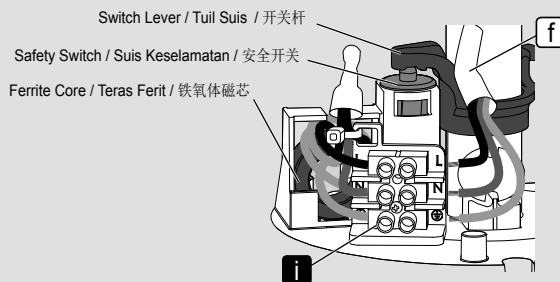

- Brown (Live) / Coklat (Hidup) / 棕色 (火线)
- Blue (Neutral) / Biru (Neutral) / 蓝色 (零线)
- Green•Yellow (Earth) / Hijau•Kuning (Bumi) / 绿色•黄色 (地线)

Connect to the power supply according to the wiring instruction below.

Sambungkan ke bekalan kuasa seperti yang ditunjukkan panduan pendawaian di bawah.

根据以下接线说明进行电源连接。

Wiring diagram / Litar pendawaian / 电线图

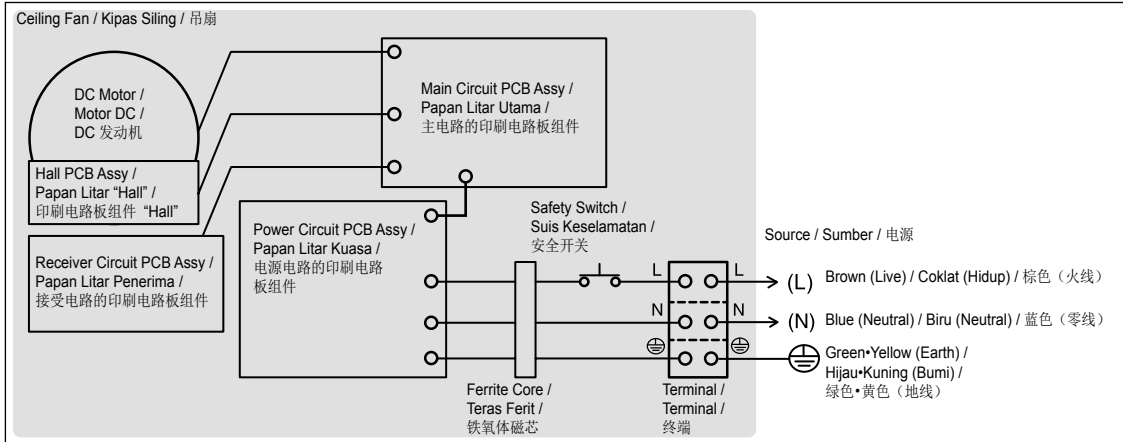

Connecting to the power supply / Sambungan ke bekalan kuasa / 电源连接

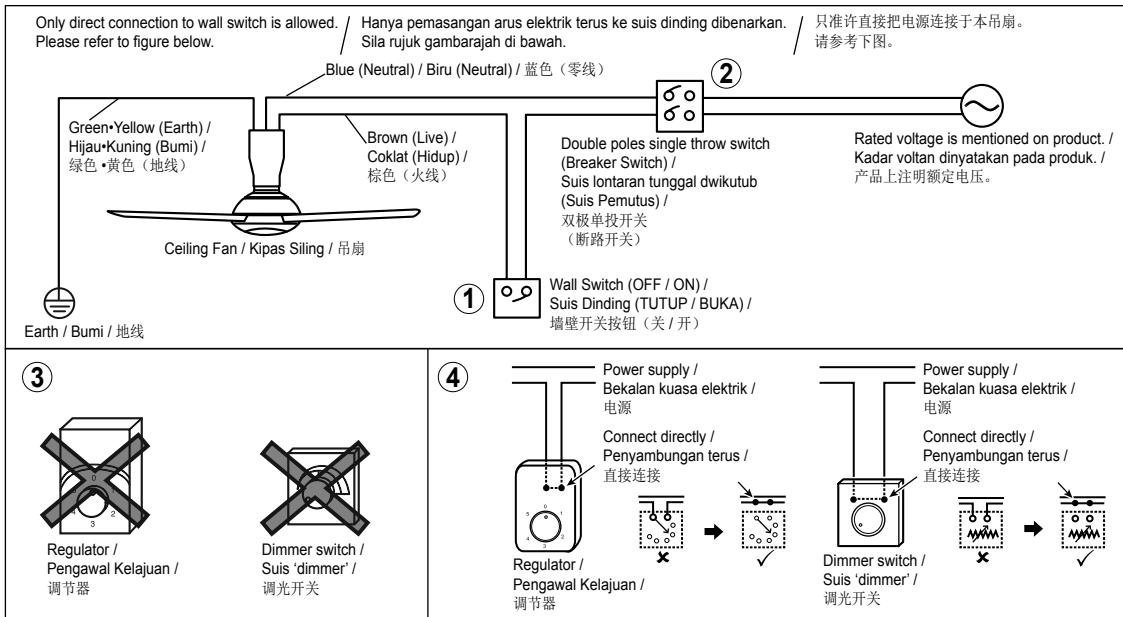

Attention:

- It is recommended to user to install OFF/ON switch on the wall for the Ceiling Fan, replacing existing regulator or new regulator point.
 - If your Remote Control missing or misplaced, the Ceiling Fan can be switched on pre set speed 5.
- This product should be installed with a double poles single throw switch (breaker switch) with a minimum of 3 mm contact gap in the fixed installation circuit.
- Do not use regulator or dimmer switch for this model. (It can damage the Ceiling Fan)
- Should there be a regulator or dimmer switch, disconnect it and reconnect the wiring as above.

Perhatian:

- Pengguna disyorkan supaya memasang suis OFF/ON di dinding untuk Kipas Siling bagi mengganti pengawal kelajuan lama atau titik pengatur baru.
 - Jika Alat Kawalan Jauh anda hilang atau salah letak, Kipas Siling boleh beroperasi pada kelajuan yang ditetapkan iaitu kelajuan 5.
- Produk ini harus dipasang dengan suis lontan tunggal dwikutub (suis pemutus) dengan ruang sentuhan sekurang-kurangnya 3 mm di litar pemasangan tetap.
- Jangan menggunakan suis 'dimmer' atau alat pengawal kelajuan. (Boleh merosakkan Kipas Siling anda)
- Sekiranya terdapat pemasangan alat pengawal kelajuan atau suis 'dimmer', putus sambungannya dan sambungkan semula pendawaian seperti di atas.

留意:

- 建议用户将吊扇的 OFF/ON 开关安装在墙壁上，替换现有的调节器或新的调节点。
 - 若您的遥控器不见了，吊扇可以以预设速度 5 开启。
- 此产品必须在固定安装电路上装上触点间隙为最少 3 mm 的双极单投开关 (断路器)。
- 切勿使用调光开关或调节器。(这会损坏吊扇)
- 若有调节器或调光开关，请按照上图拆除然后重新连接。

**WARNING**

Electrical wiring must be done by a qualified individual.
Can cause fire or electrical shock.



This product is not provided with a cord and plug or with other means for connection to the supply.
When connecting or changing the power cord or lead wire, it must be performed by a qualified person in order to avoid a hazard.
Please use 227IEC53(RVV) or thickness of tube 1 mm or above. (If there are other requirements such as the diameter of lead wire, please use according to the regulation of the country).
Can cause fire or electrical shock.



Do not bypass and short circuit the Safety Switch.
Can cause fire, electrical shock, injury or Ceiling Fan to drop.

**AMARAN**

Pendawaian elektrik mesti dipasang oleh orang yang bertauliah.
Boleh menyebabkan kebakaran atau kejutan elektrik.



Produk ini tidak dilengkapi dengan wayar dan palam atau apa-apa yang boleh memutuskan sambungan dengan bekalan kuasa. Untuk mengelakkan sebarang kecederaan, pemasangan wayar dan palam mesti dilakukan oleh orang yang berkeelayakan. Gunakan 227IEC53(RVV) atau tiub yang berketebalan lebih dari 1 mm. (Keperluan lain seperti diameter wayar, sila gunakan mengikut peraturan negara-negara berkenaan). Boleh menyebabkan kebakaran atau kejutan elektrik.



Jangan pintas dan litar pintas Suis Keselamatan.
Boleh menyebabkan kebakaran, kejutan elektrik, kecederaan atau Kipas Siling terjatuh.

**警告**

电线配线工作必须由能胜任的人员进行。
可能会导致火灾或触电。



本产品不提供电缆和插头或连接电源的其它装置。
连接或更换电缆或电线时必须由能胜任的人员进行以避免危险。请使用 227IEC53(RVV) 或厚度超过 1 mm 的导管。(其它要求, 例如电线直径等等, 请遵守相关国家的条例)。
可能会导致火灾或触电。



切勿对安全开关进行绕道和短路。
可以导致火灾、触电、受伤或吊扇掉落。

Check point after installation

- The wiring is connected properly to the power supply.

Pemeriksaan selepas pemasangan

- Pendawaian bersambung secara betul kepada bekalan kuasa.

组装后的检验点

- 电线已正确地连接了电源线。

4

Installing the Canopy

- Remove the screw (2 pieces) **J** from Upper Canopy **A** and keep it for Step 4 - ⑤.
- Align and insert the Fixing Rib **k** of the Lower Canopy **B** (2 pieces) into the Lower Canopy Fixing slot **I**. Clip it until it is fully fixed.
- Make sure Lower Canopy **B** sit properly on the slot **I** before fix Upper Canopy **A**.

Memasang Sengkuap

- Tanggalkan skru (2 batang) **J** daripada Sengkuap Atas **A** dan simpan untuk Langkah 4 - ⑤.
- Selaras dan masukkan Rusuk Tetapan **k** Sengkuap Bawah **B** (2 unit) ke dalam slot Tetapan Sengkuap Bawah **I**. Klipkannya sehingga terpasang sempurna.
- Pastikan Sengkuap Bawah **B** ditempatkan dengan betul pada slot **I** sebelum memasang Sengkuap Atas **A**.

安装罩盖

- 拆除上罩盖 **A** 上的螺丝 (2 枚) **J** 并保存直至步骤 4 - ⑤。
- 将下罩盖 **B** (2 片) 对齐固定凸缘 **k** 并插入固定凹槽 **I**。夹至完全固定。
- 在安装上罩盖 **A** 之前确保下罩盖 **B** 固定在固定凹槽 **I**。

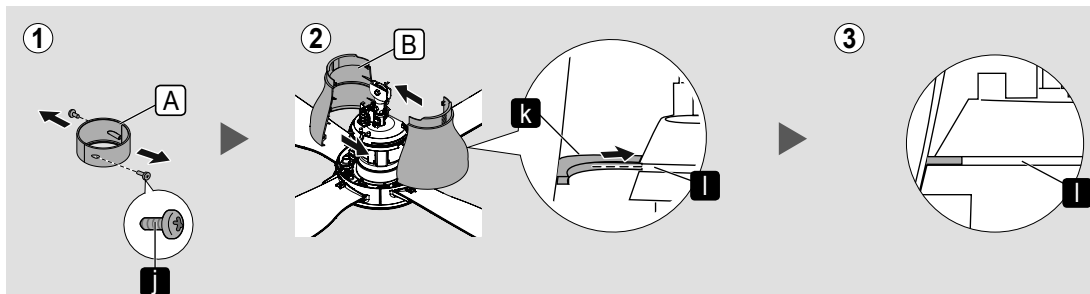

- ④ Align and insert the Fixing Rib **m** of Upper Canopy **A** into the Fixing Slot **n** of Lower Canopy **B**. Clip it until it is fully fixed. Check the gap between the Upper Canopy **A** and ceiling is approximately 5 mm or more. The gap can be adjusted by fixing the Upper Canopy **A** into different Fixing Slot **n** of Lower Canopy **B**. Ensure Upper Canopy **A** (2 pieces) is sit on top of Lower Canopy **B**.
- ⑤ Tighten the Upper Canopy **A** with the screw **j** which is removed in Step 4 - ①.

■ Attention:

- Do not assemble the Fixing Rib **m** of Upper Canopy **A** in opposite direction.
- Can cause abnormal noise.

- ④ Selaras dan masukkan Rusuk Tetapan **m** Sengkuap Atas **A** ke dalam Slot Tetapan **n** Sengkuap Bawah **B**. Klipkannya sehingga terpasang sempurna. Periksa ruang di antara Sengkuap Atas **A** dengan siling kira-kira 5 mm atau lebih. Selaraskan ruang dengan masukkan Sengkuap Atas **A** ke dalam Slot Tetapan **n** yang berlainan pada Sengkuap Bawah **B**. Pastikan Sengkuap Atas **A** (2 unit) ditempatkan di atas Sengkuap Bawah **B**.

- ⑤ Ketatkan Sengkuap Atas **A** dengan skru **j** yang ditanggalkan dalam Langkah 4 - ①.

■ Perhatian:

- Jangan pasang Rusuk Tetapan **m** Sengkuap Atas **A** secara posisi terbalik.
- Boleh menyebabkan bunyi luar biasa.

- ④ 将上罩盖 **A** 的固定凸缘 **m** 与下罩盖 **B** 的固定凹槽 **n** 对齐并插入。夹至完全固定。检查并确认上罩盖 **A** 和天花板之间的距离为 5 mm 或更多。距离可以通过上罩盖 **A** 固定到下罩盖 **B** 不同的固定凹槽 **n** 进行调整。确保上罩盖 **A** (2 片) 位于下罩盖 **B** 的顶部。
- ⑤ 用在步骤 4 - ① 拆除的螺丝 **j** 锁紧上罩盖 **A**。

■ 留意:

- 不可以反方向组装上罩盖 **A** 的固定槽 **m**。
- 可引起异响。

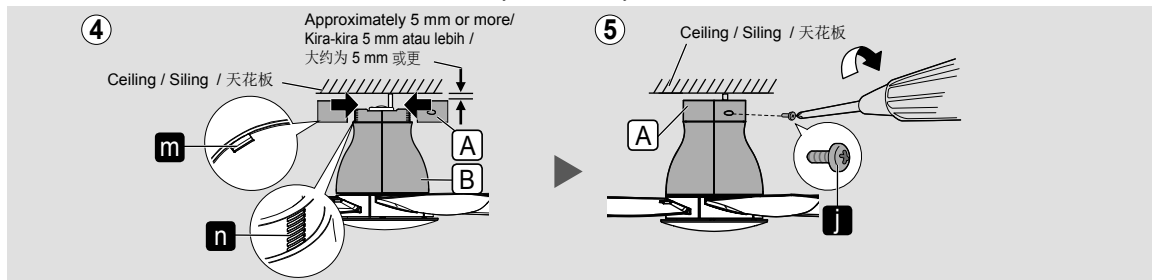

☑ Check point after installation

- The Canopy is securely screwed.

☑ Pemeriksaan selepas pemasangan

- Sengkuap diskru dengan betul.

☑ 组装后的检验点

- 罩盖牢固地拧紧。

5

■ Install Remote Control Holder

Install the Remote Control Holder Set **G** to wall. Fix the Remote Control Holder **o** using provided Screw **p** (2 pieces) and Wall Plugs **q** (2 pieces) as shown in figure below.

- Distance between holes **r** is 53 mm.
- Depth for Wall Plug **s** is 30 mm.
- Hole diameter **t** is \varnothing 6 mm.

■ Attention:

- The Wall Plugs are not needed for wooden wall.

■ Pasang Pemegang Alat Kawalan Jauh

Pasang Set Pemegang Alat Kawalan Jauh **G** pada dinding. Pasang Pemegang Alat Kawalan Jauh **o** menggunakan Skru **p** (2 batang) dan Palam Dinding **q** (2 batang) seperti rajah di bawah.

- Jarak antara lubang **r** adalah 53 mm.
- Kedalaman Palam Dinding **s** adalah 30 mm.
- Diameter lubang **t** adalah \varnothing 6 mm.

■ Perhatian:

- Palam Dinding tidak diperlukan bagi dinding kayu.

■ 安装遥控器固定器

安装遥控器固定器组件 **G** 至墙壁上。安装遥控器固定器 **o** 使用随附的螺丝 **p** (2 枚) 及墙壁插座 **q** (2 件) 如下图所示。

- 洞孔之间的距离 **r** 为 53 mm。
- 墙插插座深度 **s** 为 30 mm。
- 洞孔直径 **t** 为 \varnothing 6 mm。

■ 留意:

- 木墙不需使用墙壁插座。

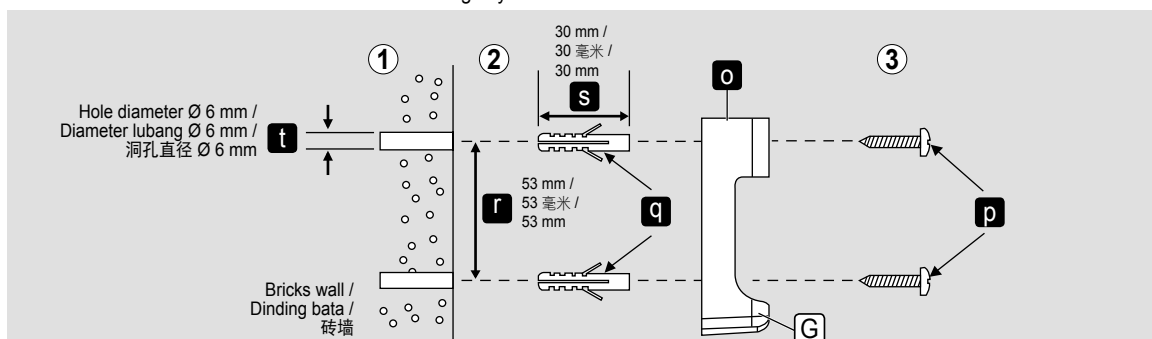

1

■ Before use

- ① Remove the Battery Cover **U** of Remote Control **F**.
- ② Insert the Batteries **E** (2 pieces AAA / R03 / LR03).
 - “+” “-” position should match.
- ③ Close the cover **U**.

■ Attention:

- Please remove all Batteries before disposing the Remote Control. The life of Battery is about one year for a normal usage.
- Replace all Batteries at one time and be careful not to mix Battery type.

■ Sebelum guna

- ① Tanggalkan Penutup Bateri **U** dari Alat Kawalan Jauh **F**.
- ② Masukkan Bateri **E** (2 unit AAA / R03 / LR03).
 - Kedudukan “+” “-” mesti dipadankan.
- ③ Pasangkan penutup **U**.

■ Perhatian:

- Sila keluarkan semua Bateri sebelum membuang Alat Kawalan Jauh. Jangka hayat Bateri adalah lebih kurang setahun untuk penggunaan normal.
- Gantikan Bateri pada tempoh penggunaan masa yang sama dan berhati-hati agar Bateri tidak bercampur.

■ 使用前

- ① 打开电池遥控器 **F** 的盖子 **U**。
- ② 插入电池 **E** (2 枚 AAA / R03 / LR03)。
 - “+” “-” 位置必须对称。
- ③ 盖好盖子 **U**。

■ 留意:

- 丢弃遥控器之前请拆除所有电池。在正常使用下, 电池的使用寿命是大约一年。
- 一次性更换所有电池并注意不要混合使用不同品牌电池。

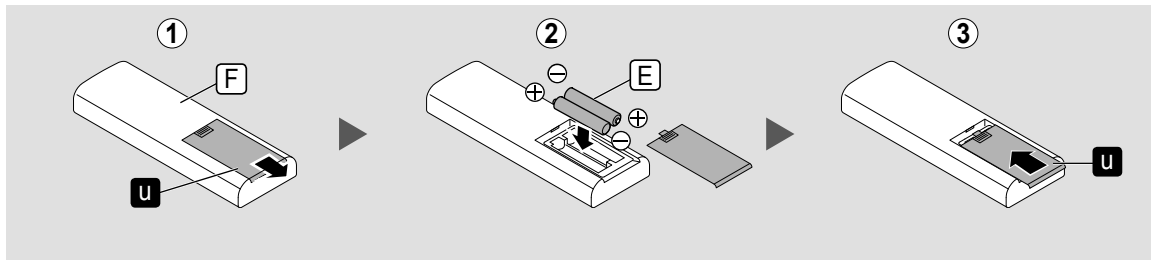

WARNING



Do not insert any metal items in the battery area with the battery.

Can cause fire or electrical shock due to short circuit.



AMARAN



Jangan masukkan sebarang logam kedalam ruang bateri bersama-sama bateri.

Boleh menyebabkan kebakaran atau kejutan elektrik akibat litar pintas.



警告



切勿把金属物体与电池一起放入电池置放处。

这可能导致火灾或电源短路而触电。

■ Attention:

- If your Remote Control missing or misplaced, the Ceiling Fan can be switched on pre set speed 5.
- If the Ceiling Fan is found to wobble during operation,
 - i.) Fix the Blades at different combination of position. Repeat this step until the Ceiling Fan stop wobbling.
 - ii.) Make sure Ceiling Fan is securely fixed on Ceiling Hook and Ceiling Fan not slanting after installation.
 - iii.) Ensure Bolt and Nut are fully tighten.
- If Ceiling Fan still wobbles after Step 2 - ④ (page 7), please refer to authorized dealer.

■ Perhatian:

- Jika Alat Kawalan Jauh anda hilang atau salah letak, Kipas Siling boleh beroperasi pada kelajuan yang ditetapkan iaitu kelajuan 5.
- Jika Kipas Siling didapati bergoyang semasa operasi,
 - i.) Tetapkan Bilah Kipas pada kombinasi kedudukan yang berlainan. Ulang langkah ini sehingga Kipas Siling berhenti bergoyang.
 - ii.) Pastikan Kipas Siling dipasang dalam keadaan selamat pada Cangkuk Siling dan Kipas Siling tidak senget selepas pemasangan.
 - iii.) Pastikan Bolt dan Nut diketatkan.
- Jika Kipas Siling masih bergoyang selepas Langkah 2 - ④ (muka surat 7), sila rujuk kepada wakil penjual.

■ 留意:

- 若您的遥控器不见了, 吊扇可以以预设速度 5 开启。
- 如果操作过程中发现吊扇摇晃,
 - i.) 将叶片的位置组合互调。重复此步骤, 直到吊扇停止摆动。
 - ii.) 确保吊扇牢固地固定在天花板钩上, 而且将吊扇安装后吊扇不呈倾斜状态。
 - iii.) 确保螺栓和螺母完全拧紧。
- 如果吊扇摇晃的情况是发生在步骤 2 - ④ (第 7 页) 之后, 请联络授权经销商。

■ Remote Control coverage ■ Lingkungan Alat Kawalan Jauh ■ 遥控器覆盖

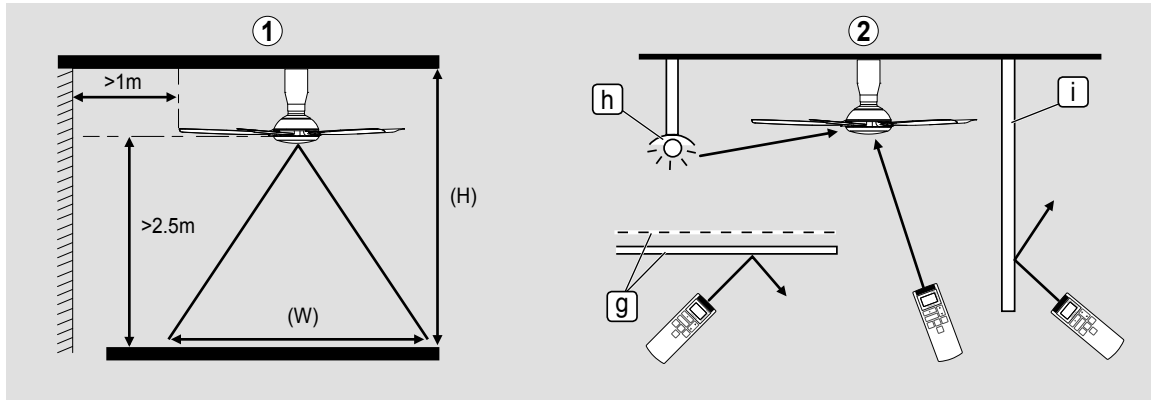

① The figure above shows the best coverage area (W) around 8 m. The ideal ceiling height (H) is 3 to 4 m. The Remote Control must be pointed to the direction of the Ceiling Fan when in use.

② Avoid the following situations:

- Netting and Glass [g] can reduce the signal power or reflect the infrared signal from the Remote Control.
- Lighting effect generated by Fluorescent Lighting Systems [h] directly onto the product receiver area can affect the signal transmission.
- Obstacles such as Walls or Glass [i] between the product receiver and Remote Control can cause signal transmission failure.

■ Attention:

- The power consumption when the operation is turned off by Remote Control is about 0.5 W.
- It is recommended to switch off wall switch or breaker if Ceiling Fan is not in use for long period. This is for zero power consumption purpose.
- Point the Remote Control directly to the desired Ceiling Fan. If 2 or more Ceiling Fan are controlled by same Remote Control, there is a possibility that the other Ceiling Fan function/setting may be change at the same time.

① Rajah di atas menunjukkan lingkungan kawalan (W) yang terbaik anggaran 8 m. Ketinggian siling (H) untuk pemasangan yang terbaik ialah 3 ke 4 m. Alat Kawalan Jauh mestilah ditunjukkan ke arah Kipas Siling ketika menggunakannya.

② Elakkan situasi yang berikut:

- Jaring dan Kaca [g] boleh mengurangkan kuasa isyarat atau memantulkan isyarat inframerah dari Alat Kawalan Jauh.
- Kesan pencahayaan terus yang dijana oleh Sistem Lampu Kalimantan [h] ke kawasan penerima produk boleh menjejaskan penghantaran isyarat.
- Halangan seperti Dinding atau Kaca [i] di antara penerima produk dengan Alat Kawalan Jauh boleh menyebabkan kegagalan penghantaran isyarat.

■ Perhatian:

- Penggunaan kuasa apabila operasi kipas dimatikan oleh Alat Kawalan Jauh ialah kira-kira 0.5 W.
- Adalah digalakkan untuk mematikan suis dinding atau pemutus pendawaian jika Kipas Siling tidak digunakan dalam jangka masa yang lama. Ini adalah untuk mengelakkan sebarang pembaziran kuasa elektrik.
- Tuju Alat Kawalan Jauh ke arah Kipas Siling yang dikehendaki. Jika 2 atau lebih Kipas Siling dikawal oleh Alat Kawalan Jauh yang sama, ada kebarangkalian bahawa fungsi/tetapan Kipas Siling yang lain mungkin berubah pada masa yang sama.

① 上图显示最佳覆盖范围 (W) 约 8 m。最佳天花板高度 (H) 是 3~4 m。使用时, 遥控器必须指向吊扇的方向。

② 避免以下的情形:

- 网和玻璃 [g] 会减低信号功率或反射自遥控器的红外信号。
- 荧光照明系统 [h] 产生的照明效果直射在产品接收器区域上会影响信号传送。
- 在产品接收器和遥控器之间如墙壁或玻璃 [i] 的障碍物可能导致信号传送故障。

■ 留意:

- 吊扇操作被遥控器关闭时的电源消耗是大约 0.5 W。
- 若长时间不使用吊扇, 建议您关闭墙壁开关或断路器。以达到零电源消耗的目的。
- 将遥控器直接指向需打开的吊扇。如果该遥控器同时控制两个或更多个吊扇, 各吊扇的功能/设定都可能同时被改变。

■ How to use Remote Control

■ Cara penggunaan Alat Kawalan Jauh

■ 如何使用遥控器

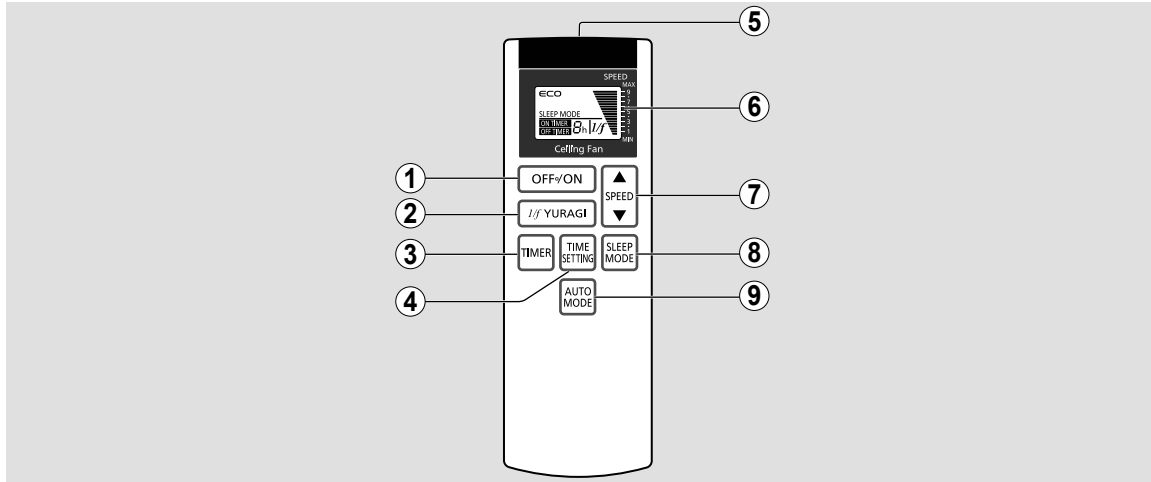

① OFF/ON Button

Press to activate or stop the Ceiling Fan.
“ON” - Short beeping sound.
“OFF” - Long beeping sound.

② 1/f YURAGI Button

Press to activate 1/f YURAGI mode.
“1/f” will be shown in LCD screen.

③ TIMER Button

Press to select ON TIMER or OFF TIMER.
ON TIMER : To turn ON the Ceiling Fan according to the time and speed setting.
(On Timer LED light at Ceiling Fan will be turned on).
Refer to 5 on page 16.
OFF TIMER : To turn OFF the Ceiling Fan according to the time and speed setting.
Refer to 6 on page 16.

④ TIME SETTING Button

Press to select the OFF TIMER and ON TIMER from 1 hour to 8 hour.

⑤ Transmitter

⑥ LCD Display Screen

⑦ SPEED Button

Press SPEED button ▲ to increase or ▼ decrease fan speed. Minimum fan speed is 1, maximum fan speed is 9.

⑧ SLEEP MODE Button

To stop the Ceiling Fan according to the time setting.
For SLEEP MODE function, refer to 7 on page 16.

⑨ AUTO MODE Button

Press to activate or to stop ECO MODE.
“ECO” will be shown on LCD Display Screen.

① Butang OFF/ON

Tekan untuk Kipas Siling berpusing atau berhenti.
“ON” - Bunyi “Beep” yang pendek.
“OFF” - Bunyi “Beep” yang panjang.

② Butang 1/f YURAGI

Tekan untuk mengaktifkan mod 1/f YURAGI.
“1/f” akan ditunjukkan pada skrin LCD.

③ Butang PEMASA

Tekan untuk memilih PEMASA BUKA atau PEMASA TUTUP.
PEMASA BUKA : Untuk membuka Kipas Siling mengikut tetapan masa dan kelajuan.
(Lampu LED On Timer pada Kipas Siling akan menyala). Rujuk 5 pada muka surat 16.
PEMASA TUTUP : Untuk menghentikan Kipas Siling mengikut tetapan masa dan kelajuan. Rujuk 6 pada muka surat 16.

④ Butang PENGATURAN MASA

Tekan untuk memilih PEMASA TUTUP dan PEMASA BUKA dari 1 jam hingga 8 jam.

⑤ Pemancar

⑥ Paparan Skrin LCD

⑦ Butang KELAJUAN

Tekan butang SPEED ▲ untuk menambah atau ▼ mengurangkan kelajuan kipas. Kelajuan kipas minimum adalah 1, kelajuan kipas maksimum adalah 9.

⑧ Butang MOD TIDUR

Untuk menghentikan Kipas Siling mengikut tetapan masa.
Untuk fungsi MOD TIDUR, rujuk 7 pada muka surat 16.

⑨ Butang MOD AUTO

Tekan untuk mengaktifkan atau mematikan MOD ECO.
“ECO” akan ditunjukkan pada paparan skrin LCD.

① OFF/ON 按钮

按启动或停止吊扇。
“ON” - 发出短促的“哔”声。
“OFF” - 发出长长的“哔”声。

② 1/f YURAGI 按钮

按下以启动的 1/f YURAGI 模式。
“1/f” 将在 LCD 显示屏显示出来。

③ 计时器按钮

按下以选择启动计时器或关闭计时器。
启动计时器：根据该时间和速度设定启动吊扇。（吊扇的 On Timer LED 灯将被开启）。
请参阅 5 第 16 页。
关闭计时器：根据该时间和速度设定关闭吊扇。
请参阅 6 第 16 页。

④ 时间设定按钮

按了之后选择关闭计时器和开启计时器，1 小时至 8 小时。

⑤ 发送器

⑥ LCD 显示屏

⑦ 速度按钮

按 SPEED 按钮 ▲ 以提高或 ▼ 减低风量。最低风量为 1，最高风量为 9。

⑧ 睡眠模式按钮

根据该时间设定停止吊扇。
关于睡眠模式功能，请参阅 7 第 16 页。

⑨ 自动模式按钮

按下以启动或停止 ECO 模式。
“ECO” 将在 LCD 显示屏显示出来。

■ LCD Display

■ Paparan LCD

■ 显示屏

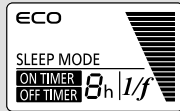

LCD full display /
Paparan penuh LCD /
LCD 显示屏全显示

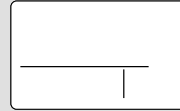

LCD display is OFF /
Paparan LCD dipadamkan /
LCD 显示屏关闭

Figure above shows that LCD Display is in off condition when OFF/ON button on Remote Control Unit is pressed.

Rajah di atas menunjukkan Paparan LCD berada dalam keadaan dipadamkan apabila butang OFF/ON pada Alat Kawalan Jauh ditekan.

上图所示，当按下遥控器的 OFF/ON 按钮时，LCD 显示屏关闭。

■ Speed Display

■ Paparan Kelajuan

■ 速度显示

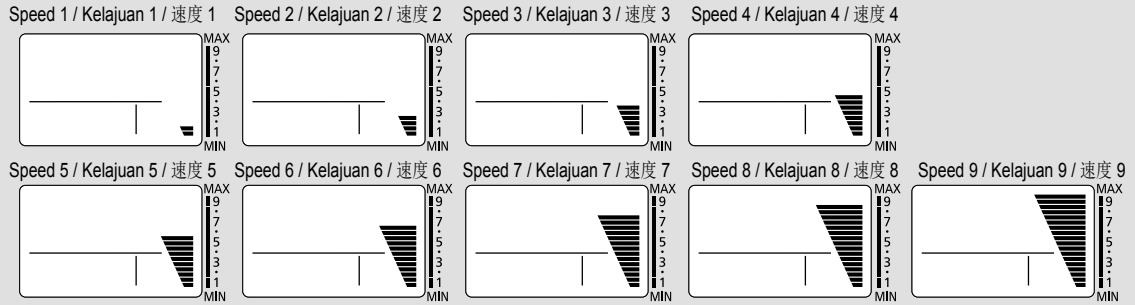

■ Timer Display

■ Paparan Pemasa

■ 计时器显示

1 hours / 1 jam / 1 小时

1h

2 hours / 2 jam / 2 小时

2h

3 hours / 3 jam / 3 小时

3h

4 hours / 4 jam / 4 小时

4h

5 hours / 5 jam / 5 小时

5h

6 hours / 6 jam / 6 小时

6h

7 hours / 7 jam / 7 小时

7h

8 hours / 8 jam / 8 小时

8h

OFF TIMER /
PEMASA TUTUP /
关闭计时器



OFF TIMER is ON /
PEMASA TUTUP DIAKTIFKAN /
关闭计时器开启

ON TIMER /
PEMASA BUKA /
启动计时器

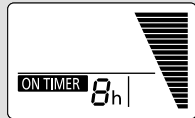

ON TIMER is ON /
PEMASA BUKA DIAKTIFKAN /
启动计时器开启

SLEEP MODE /
MOD TIDUR /
睡眠模式

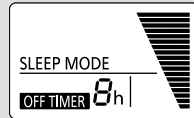

SLEEP MODE is ON /
MOD TIDUR DIAKTIFKAN /
睡眠模式开启

1/f YURAGI /
1/f YURAGI /
1/f YURAGI



1/f YURAGI is ON /
1/f YURAGI DIAKTIFKAN /
1/f YURAGI 开启

ECO MODE /
MOD ECO /
ECO 模式



ECO MODE is ON /
MOD ECO DIAKTIFKAN /
ECO 模式开启

4

■ 1/f YURAGI (natural breeze)

Add smooth accent to air capacity and comfortable wind more naturally. To activate 1/f YURAGI function according to speed setting.

- ① Select a desired speed (speed 1~9).
- ② Press "1/f YURAGI" button on Remote Control to activate 1/f YURAGI function.
 - Press again to deactivate 1/f YURAGI function.

■ 1/f YURAGI (angin semula jadi)

Menambahkan angin lebih nyaman dan selesa seperti angin semula jadi. Untuk mengaktifkan fungsi 1/f YURAGI mengikut kelajuan yang ditetapkan.

- ① Pilih kelajuan yang diinginkan (kelajuan 1~9).
- ② Tekan butang "1/f YURAGI" pada Alat Kawalan Jauh untuk mengaktifkan fungsi 1/f YURAGI.
 - Tekan sekali lagi untuk mematikan fungsi 1/f YURAGI.

■ 1/f YURAGI (自然微风)

为吹出的风加入柔和气氛，使舒适的风显得更自然。若要按照该速度设置启动 1/f YURAGI 功能。

- ① 选择所需的速度（速度 1~9）。
- ② 按遥控器上的 "1/f YURAGI" 按钮以启动 1/f YURAGI 功能。
 - 再次按下以关闭 1/f YURAGI 功能。

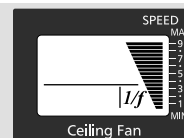
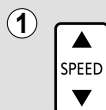

1/f YURAGI speed change pattern

Bentuk perubahan kelajuan 1/f YURAGI

1/f YURAGI 速度转换模式

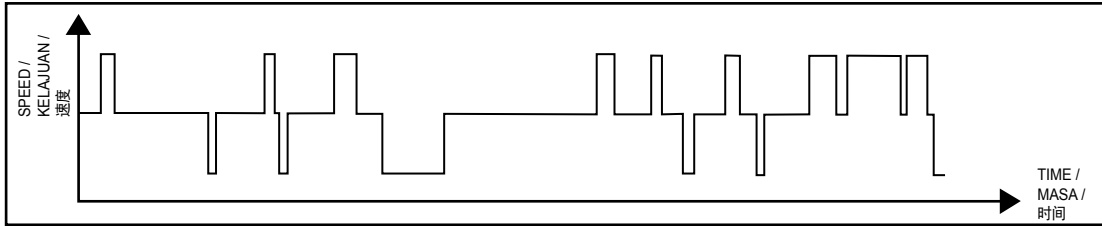

This pattern is an example for 1/f YURAGI setting at speed 4.

■ Note:

- 1/f YURAGI function does exist for speed 1 but less noticeable compared to higher speed (speed 4 and above).

Bentuk ini menunjukkan contoh penetapan 1/f YURAGI pada kelajuan 4.

■ Nota:

- Fungsi 1/f YURAGI terdapat pada kelajuan 1 tetapi kurang dapat dirasa berbanding pada kelajuan lebih tinggi (kelajuan 4 dan ke atas).

这模式示范速度 4 时的 1/f YURAGI 设置。

■ 备注:

- 速度 1 有 1/f YURAGI 功能，但是相对较高速度时（速度 4 和以上）并不明显。

ON TIMER

The Timer will hourly count down until fan is switched ON.

- During this timer count down, fan will remain OFF until count down is completed.

- ① Step 1: Select a desired speed (speed 1 ~ 9), 1/f YURAGI or AUTO MODE.
- ② Step 2: Press "TIMER" button to select ON TIMER (On Timer LED light at Ceiling Fan will be turned on).
- ③ Step 3: Press "TIME SETTING" button to select desired time frame (1 ~ 8 hours).

PEMASA BUKA

Pemasa akan turun beransur-ansur dari sejam ke sejam sehingga terbuka.

- Semasa kiraan pemasa menurun, kipas akan tetap tertutup sehingga kiraan menurun tamat.

- ① Langkah 1: Pilih kelajuan yang diinginkan (kelajuan 1 ~ 9), 1/f YURAGI atau MOD AUTO.
- ② Langkah 2: Tekan butang "TIMER" untuk memilih PEMASA BUKA (Lampu LED On Timer pada Kipas Siling akan menyala).
- ③ Langkah 3: Tekan butang "TIME SETTING" untuk memilih rangka masa yang diinginkan (1 ~ 8 jam).

启动计时器

计时器将开始每小时逐渐倒数至启动。

- 计时器倒数期间，吊扇保持关闭直到倒数完成。

- ① 步骤 1：选择所需的速度（速度 1 ~ 9），1/f YURAGI 或自动模式。
- ② 步骤 2：按 "TIMER" 按钮即可选择开启计时器（吊扇的 On Timer LED 灯将被开启）。
- ③ 步骤 3：按 "TIME SETTING" 按钮，按钮选择所需的时间（1 ~ 8 小时）。



OFF TIMER

The Timer will hourly count down until fan is switched OFF.

- During this timer count down, speed will remain the same until the Ceiling Fan is OFF.

- ① Step 1: Select a desired speed (speed 1 ~ 9), 1/f YURAGI or AUTO MODE.
- ② Step 2: Press "TIMER" button to select OFF TIMER.
- ③ Step 3: Press "TIME SETTING" button to select desired time frame (1 ~ 8 hours).

PEMASA TUTUP

Pemasa akan turun beransur-ansur dari sejam ke sejam sehingga tertutup.

- Semasa kiraan pemasa menurun, kelajuan akan tetap sama sehingga Kipas Siling tertutup.

- ① Langkah 1: Pilih kelajuan yang diinginkan (kelajuan 1 ~ 9), 1/f YURAGI atau MOD AUTO.
- ② Langkah 2: Tekan butang "TIMER" untuk memilih PEMASA TUTUP.
- ③ Langkah 3: Tekan butang "TIME SETTING" untuk memilih rangka masa yang diinginkan (1 ~ 8 jam).

关闭计时器

计时器将开始每小时逐渐倒数至关闭。

- 计时器倒数期间，速度会保持不变直到吊扇关闭。

- ① 步骤 1：选择所需的速度（速度 1 ~ 9），1/f YURAGI 或自动模式。
- ② 步骤 2：按 "TIMER" 按钮即可关闭计时器
- ③ 步骤 3：按 "TIME SETTING" 按钮，按钮选择所需的时间（1 ~ 8 小时）。



SLEEP MODE

Ceiling Fan speed and timer will gradually reduce until the Ceiling Fan is OFF.

Refer SLEEP MODE chart on page 17.

- During this timer count down, speed will go down until the Ceiling Fan is OFF.

- ① Step 1: Select a desired speed (speed 2 ~ 9) or 1/f YURAGI.
- ② Step 2: Press "TIMER" button to select OFF TIMER. SLEEP MODE will only shown with OFF TIMER turn on.

MOD TIDUR

Kelajuan Kipas Siling dan pemasa akan berkurangan beransur-ansur sehingga Kipas Siling tertutup.

Rujuk carta MOD TIDUR pada muka surat 17.

- Semasa kiraan pemasa menurun, kelajuan akan menurun sehingga Kipas Siling tertutup.

- ① Langkah 1: Pilih kelajuan yang diinginkan (kelajuan 2 ~ 9) atau 1/f YURAGI.
- ② Langkah 2: Tekan butang "TIMER" untuk memilih PEMASA TUTUP. MOD TIDUR akan ditayangkan dengan PEMASA TUTUP diaktifkan.

睡眠模式

吊扇的速度以及计时器将逐渐递减直到吊扇完全停止。

请参阅第 17 页“睡眠模式”图表。

- 计时器倒数期间，吊扇的速度将逐渐缓慢下来直到关闭吊扇。

- ① 步骤 1：选择所需的速度（速度 2 ~ 9）或 1/f YURAGI。
- ② 步骤 2：按 "TIMER" 按钮即可关闭计时器。睡眠模式只有在关闭计时器后才显示。

5

6

7

③ Step 3 : Press "TIME SETTING" button to select desired time frame (2 ~ 8 hours).

④ Step 4 : Press "SLEEP MODE" button. "SLEEP MODE" will be shown on LCD Display screen. SLEEP MODE is ON.

③ Langkah 3 : Tekan butang "TIME SETTING" untuk memilih rangka masa yang diinginkan (2 ~ 8 jam).

④ Langkah 4 : Tekan butang "SLEEP MODE". "SLEEP MODE" akan ditunjukkan pada Paparan skrin LCD. MOD TIDUR telah diaktifkan.

③ 步骤 3 : 按 "TIME SETTING" 按钮选择所需的时间 (2 ~ 8 小时)。

④ 步骤 4 : 按 "SLEEP MODE" 按钮。"SLEEP MODE" 将在 LCD 显示屏显示出来。睡眠模式开启。

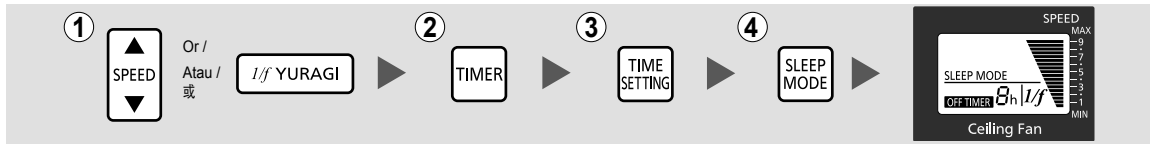

Timer / Pemas / 计时器	8h	7h	6h	5h	4h	3h	2h	1h	0h
Speed 9 / Kelajuan 9 / 速度 9	9	→	7	→	5	→	3	→	
		9	→	7	→	5	→	3	
			9	→	7	→	5	→	
				9	→	7	→	5	
Speed 8 / Kelajuan 8 / 速度 8	8	→	6	→	4	→	2	→	
		8	→	6	→	4	→	2	
			8	→	6	→	4	→	
				8	→	6	→	4	
Speed 7 / Kelajuan 7 / 速度 7	7	→	5	→	3	→	1	→	
		7	→	5	→	3	→	1	
			7	→	5	→	3	→	
				7	→	5	→	3	
Speed 6 / Kelajuan 6 / 速度 6	6	→	4	→	2	→	1	→	
		6	→	4	→	2	→	1	
			6	→	4	→	2	→	
				6	→	4	→	2	
Speed 5 / Kelajuan 5 / 速度 5	5	→	3	→	1	→	→	→	
		5	→	3	→	1	→	→	
			5	→	3	→	1	→	
				5	→	3	→	1	
Speed 4 / Kelajuan 4 / 速度 4	4	→	2	→	1	→	→	→	
		4	→	2	→	1	→	→	
			4	→	2	→	1	→	
				4	→	2	→	1	
Speed 3 / Kelajuan 3 / 速度 3	3	→	1	→	→	→	→	→	
		3	→	1	→	→	→	→	
			3	→	1	→	→	→	
				3	→	1	→	→	
Speed 2 / Kelajuan 2 / 速度 2	2	→	1	→	→	→	→	→	
		2	→	1	→	→	→	→	
			2	→	1	→	→	→	
				2	→	1	→	→	

OFF / TUTUP / 关闭

■ Note:

- SLEEP MODE function is disabled at Speed 1 and 1 hour setting, and ECO MODE.
- SLEEP MODE will be deactivated, if TIMER SETTING is changed.

■ Nota:

- MOD TIDUR tidak berfungsi pada tetapan Kelajuan 1 dan 1 jam, dan MOD ECO.
- MOD TIDUR akan terbatal jika TETAPAN PEMASA diubah.

■ 备注:

- 速度1, 1小时的设置以及 ECO 模式都无法使用睡眠模式。
- 如果改变定时器的设置, 睡眠模式功能将被取消。

■ ECO MODE

ECO MODE function is to control suitable air velocity to human.

It will function based on changing of room temperature.

Air velocity will increase when room temperature in high temperature and reduce when room in low temperature.

■ Note:

- The room temperature varies at different location in a room.
- ECO MODE sensor only detects the room temperature around the sensor position.
- Fan speed adjustment will start after ECO MODE is activated for 10 minutes.
- Afterwards, ECO MODE sensor will undergo temperature detection in every 10 minutes for fan speed adjustment.

① Select a desired speed (speed 1~9).

- Selected speed will be ECO MODE initial speed.

② Press "AUTO MODE" button on Remote Control to activate ECO MODE function.

Sensor LED light at Ceiling Fan will be turned on.

- Press again to deactivate ECO MODE. Fan speed will return to initial speed.

■ MOD ECO

Fungsi MOD ECO adalah untuk mengawal halaju angin yang sesuai untuk manusia.

Ia akan berfungsi berdasarkan perubahan suhu bilik.

Halaju angin akan bertambah apabila suhu bilik tinggi dan berkurang apabila suhu bilik rendah.

■ Nota:

- Suhu bilik berlainan pada tempat yang berbeza dalam sebuah bilik.
- Penganasan MOD ECO hanya mengesan suhu bilik di sekeliling kedudukan penganasan.
- Perubahan kelajuan kipas akan mula selepas MOD ECO diaktifkan selama 10 minit.
- Selepas itu, penganasan MOD ECO akan mengesan suhu setiap 10 minit bagi mengubah kelajuan kipas.

① Pilih kelajuan yang diingini (kelajuan 1~9).

- Kelajuan yang dipilih akan menjadi kelajuan asal MOD ECO.

② Tekan butang "AUTO MODE" pada Alat Kawalan Jauh untuk mengaktifkan fungsi MOD ECO. Lampu LED Sensor pada Kipas Siling akan menyala.

- Tekan sekali lagi untuk mematikan fungsi MOD ECO. Kelajuan kipas akan kembali pada kelajuan asal.

■ ECO 模式

ECO 模式功能是控制适合对人类的风速。

它将功能基于室内温度的变化。

风速将增加当室温在高的温度和减少当室温降低在低的温度。

■ 备注:

- 在一个房间里，不同的位置，房间的温度各不相同。
- ECO 模式感应器只检测室温感应器位置附近。
- 风量将在 ECO 模式启动后的 10 分钟开始进行调整。
- 随后，ECO 模式感应器将每 10 分钟检测温度一次以调节风量。

① 选择所需的速度（速度 1~9）。

- 选定的速度将是 ECO 模式初始的速度。

② 按遥控器上的 "AUTO MODE" 按钮以启动 ECO 模式功能。

吊扇的 Sensor LED 灯将被开启。

- 再次按下以关闭 ECO 模式。风量将恢复到初始速度。



■ Note:

- Speed cannot be changed during ECO MODE activated.
- SLEEP MODE cannot be activated during the operation of ECO MODE.

■ Nota:

- Kelajuan tidak boleh diubah semasa MOD ECO diaktifkan.
- MOD TIDUR tidak boleh diaktifkan semasa fungsi MOD ECO beroperasi.

■ 备注:

- 速度不能在 ECO 模式启动时更改。
- “睡眠模式”不能在 ECO 模式的操作期间被启动。

Room Temperature / Suhu Bilik / 室温		Speed Change / Perubahan Kelajuan / 速度转换
Range / Lingkungan / 范围	Variation / Perubahan / 差异	
Above 30° C / Tinggi daripada 30° C / 30° C 以上	Approximately +1° C / Kira-kira +1° C / 大约 +1° C	2 Speed Up / 2 Kelajuan Bertambah / 增加 2 速
	Approximately -1° C / Kira-kira -1° C / 大约 -1° C	2 Speed Down / 2 Kelajuan Berkurang / 减少 2 速
29° C ≤ Room Temperature < 30° C / 29° C ≤ Suhu Bilik < 30° C / 29° C ≤ 室温 < 30° C	Approximately +1° C / Kira-kira +1° C / 大约 +1° C	2 Speed Up / 2 Kelajuan Bertambah / 增加 2 速
	Approximately -1° C / Kira-kira -1° C / 大约 -1° C	1 Speed Down / 1 Kelajuan Berkurang / 减少 1 速
24° C ≤ Room Temperature < 29° C / 24° C ≤ Suhu Bilik < 29° C / 24° C ≤ 室温 < 29° C	Approximately +1° C / Kira-kira +1° C / 大约 +1° C	1 Speed Up / 1 Kelajuan Bertambah / 增加 1 速
	Approximately -1° C / Kira-kira -1° C / 大约 -1° C	1 Speed Down / 1 Kelajuan Berkurang / 减少 1 速
Below 24° C / Rendah daripada 24° C / 24° C 以下	Approximately +1° C / Kira-kira +1° C / 大约 +1° C	Speed does not change / Kelajuan tidak berubah / 速度没有改变
	Approximately -1° C / Kira-kira -1° C / 大约 -1° C	

■ **Note:**

• Controlling of speed change for ECO MODE function is between speed 1 to speed 9.

■ **Nota:**

• Kawalan perubahan kelajuan untuk fungsi MOD ECO adalah antara kelajuan 1 hingga kelajuan 9.

■ **备注:**

• ECO 模式功能的速度转换控制是速度 1 至速度 9 之间。

Example for ECO MODE Function.

Contoh Fungsi MOD ECO.

ECO 模式功能的例子。

- ① Operating in high room temperature.
- ② Operating in low room temperature.

- ① Operasi dalam bilik bersuhu tinggi.
- ② Operasi dalam bilik bersuhu rendah.

- ① 在高室温内操作。
- ② 在低室温内操作。

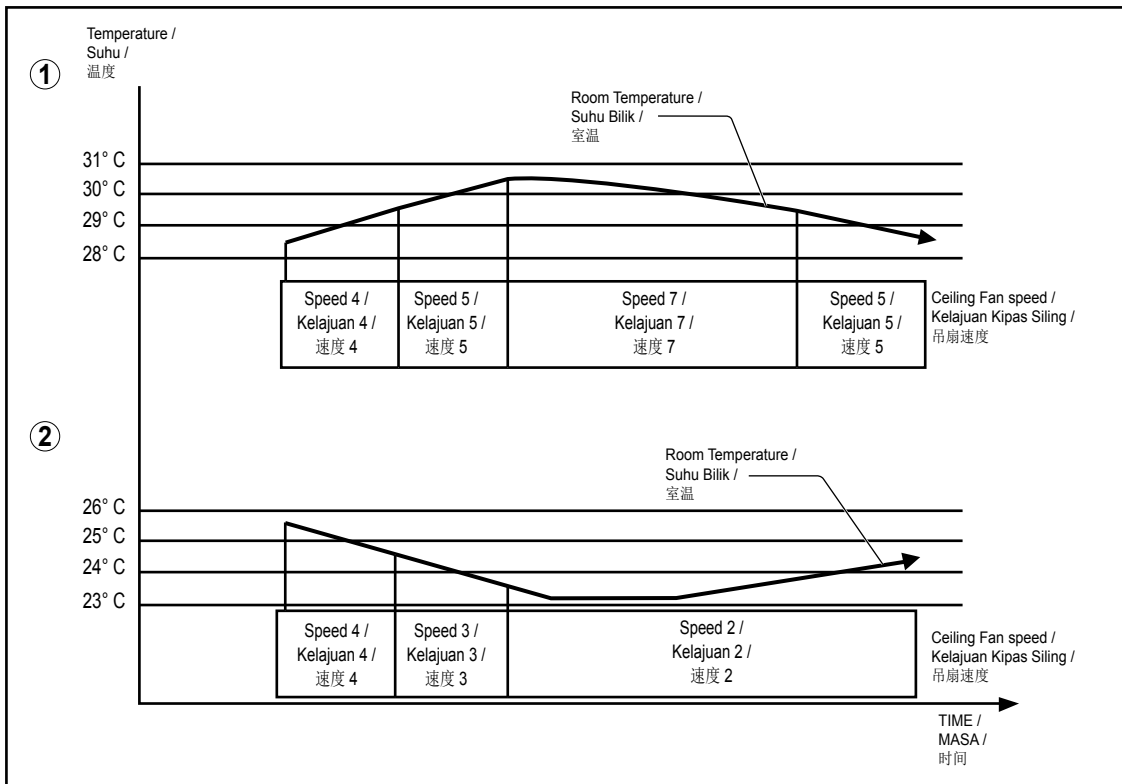

Maintenance

Penyelenggaraan

维修

- ① **Check the Ceiling Fan condition annually. If a problem occurs, stop using the Ceiling Fan. Then refer to authorized dealer.**

□ **Check point:**

Loosened screws, safety wire condition, motor shaft damage, etc.

- ② **Ensure Safety Switch in good condition. If a problem occurs, stop using the Ceiling Fan. Then refer to authorized dealer.**

- ① **Periksa keadaan Kipas Siling sekali setahun. Jika masalah berlaku, berhenti menggunakan Kipas Siling. Kemudian rujuk kepada wakil penjual.**

□ **Pemeriksaan:**

Skru longgar, keadaan wayar keselamatan, kerosakan aci motor, dsb.

- ② **Pastikan Suis Keselamatan dalam keadaan baik. Jika masalah berlaku, berhenti menggunakan Kipas Siling. Kemudian rujuk wakil penjual.**

- ① 请每年定时检查吊扇的状况。如果出现问題，请停止使用有关吊扇，然后质询授权经销商。

□ **检查点:**

螺丝松脱、保险线状况、发动机转动轴损坏等等。

- ② 确保安全开关处于良好状态。如果出现问題，停止使用有关吊扇。然后质询授权经销商。

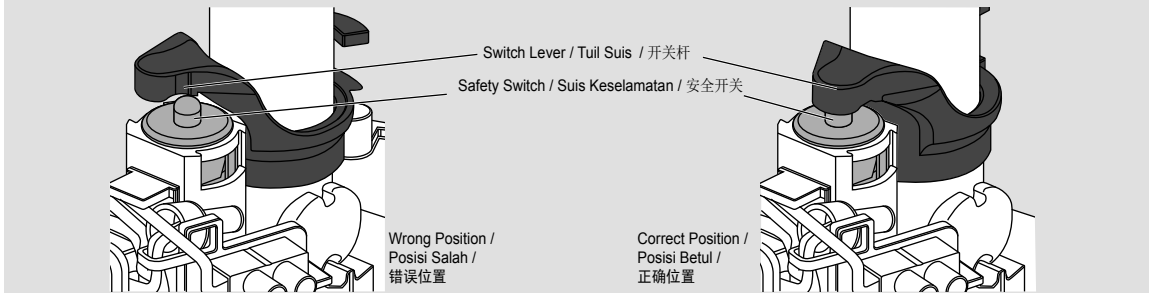

- ③ **Keep the Ceiling Fan clean. Wipe away dirt with a clean soft cloth, ordinary soap and water. Wipe it again to dry it. Do not use solvents (gasoline, petroleum, thinner, benzene, alcohol, cleaning powder, alkaline detergent) or any other chemicals.**

• Do not bend the Blade while cleaning.

- ④ **Do not paint the Blades. If damaged, order a new set of Blades (4 pieces) from an authorized dealer.**

- ⑤ **When referring to an authorized dealer, show these instructions to them so that maintenance will be done correctly.**

- ⑥ **If the product is broken or damaged, remove it from the ceiling and replace with new. This is to avoid the Ceiling Fan drops.**

- ⑦ **The Ceiling Fan suspension system should be examined at least once every two years.**

- ③ **Kekalkan kebersihan Kipas Siling. Mengelap kotoran dengan menggunakan kain yang bersih dan lembut, sabun biasa dan air. Lapkan sekali lagi untuk mengeringkannya. Jangan gunakan pelarut (gasolin, petrol, pencair, benzin, alkohol, serbuk pencuci, detergen alkali) atau bahan kimia lain.**

• Jangan bengkokkan Bilah Kipas ketika membersihkan.

- ④ **Jangan cat Bilah Kipas. Jika ada kerosakan, pesan set Bilah Kipas baru (4 unit) daripada wakil penjual.**

- ⑤ **Apabila merujuk kepada wakil penjual, tunjukkan arahan ini kepada mereka agar penyelenggaraan yang betul dapat dijalankan.**

- ⑥ **Jika produk pecah atau rosak, sila tanggalkannya dari siling dan gantikan dengan kipas baru. Ini adalah untuk mengelakkan Kipas Siling terjatuh.**

- ⑦ **Disarankan memeriksa sistem gantungan Kipas Siling sekurang-kurangnya setiap dua tahun sekali.**

- ③ 保持吊扇清洁。用干净的软布、普通肥皂和水抹去污渍。再抹一次将之抹干。切勿使用溶剂（汽油、石油、稀释剂、苯、酒精、去污粉和碱性洗涤剂）或任何其他化学物品。

• 清洗扇翼时请切勿折弯扇翼。

- ④ 切勿为扇翼涂漆。若扇翼损坏了，请授权经销商订购新的扇翼（4片）。

- ⑤ 当您质询授权经销商时，请向他们出示此指示以便他们正确地进行维修。

- ⑥ 若产品已折断或损坏，请从天花板上拆除吊扇，然后换上新的吊扇。这是为了防止吊扇掉落。

- ⑦ 建议每两年至少检查吊扇悬挂系统一次。

Specifications

Spesifikasi

规格

Voltage (VAC)	Voltan (VAC)	电压 (VAC)	240
Frequency (Hz)	Frekuensi (Hz)	频率 (Hz)	50
Wattage (W)	Kuasa (W)	瓦特数 (W)	2.5 / 41
Speed 1 / Speed 9	Kelajuan 1 / Kelajuan 9	速度 1 / 速度 9	
Rotation (RPM)	Putaran (RPM)	旋转度 (RPM)	81 / 239
Speed 1 / Speed 9	Kelajuan 1 / Kelajuan 9	速度 1 / 速度 9	
Air Velocity (m/min)	Halaju Angin (m/min)	风速 (m/min)	185
Air Delivery (m ³ /min)	Sebaran Angin (m ³ /min)	送风量 (m ³ /min)	225
Net Weight (kg)	Berat Bersih (kg)	净重 (kg)	4.9

Manufactured for:-

KDK FANS (M) SDN. BHD. (568849X)

15, Jalan Tandang (3rd Floor),
46050 Petaling Jaya, Selangor Darul Ehsan.

Made in Malaysia

K14ZW8001ZM

M0116-0